

8-1987

Appendices to analysis of the water-quality standards proposed by Nevada Division of Environmental Protection

State of Nevada: Division of Environmental Protection

Follow this and additional works at: https://digitalscholarship.unlv.edu/water_pubs



Part of the [Environmental Health and Protection Commons](#), [Environmental Indicators and Impact Assessment Commons](#), [Environmental Monitoring Commons](#), [Fresh Water Studies Commons](#), [Natural Resources Management and Policy Commons](#), and the [Water Resource Management Commons](#)

Repository Citation

State of Nevada: Division of Environmental Protection (1987). Appendices to analysis of the water-quality standards proposed by Nevada Division of Environmental Protection.

Available at: https://digitalscholarship.unlv.edu/water_pubs/76

This Technical Report is protected by copyright and/or related rights. It has been brought to you by Digital Scholarship@UNLV with permission from the rights-holder(s). You are free to use this Technical Report in any way that is permitted by the copyright and related rights legislation that applies to your use. For other uses you need to obtain permission from the rights-holder(s) directly, unless additional rights are indicated by a Creative Commons license in the record and/or on the work itself.

This Technical Report has been accepted for inclusion in Publications (WR) by an authorized administrator of Digital Scholarship@UNLV. For more information, please contact digitalscholarship@unlv.edu.

APPENDICES TO

ANALYSIS OF

THE WATER-QUALITY STANDARDS

PROPOSED BY

THE NEVADA DIVISION OF ENVIRONMENTAL PROTECTION

AUGUST 1987

Errata Sheet for ANALYSIS OF THE WATER-QUALITY STANDARDS PROPOSED BY
THE NEVADA DIVISION OF ENVIRONMENTAL PROTECTION, Submitted by the
City of Las Vegas, August 1987

<u>Page/Line</u>	<u>Change To:</u>
ii/27-28	Phosphorus Removal Has Cost \$170 Million
2/8	phosphorus. However, the wastewater-treatment plants operated
2/11	Although \$170 million (equivalent present value) has been spent on phosphorus removal,
7/9-12	Building and operating facilities for phosphorus removal have cost more than \$170 million so far (equivalent present value and operational costs).
12/7	also includes a study of algal ecology in the bay and of the
18/25	with relatively higher algal populations grow proportionately
37/9	upon much of the shallow lake bottom . . .
45/7	What effect did the decrease in phosphorus
48/14	or away from, the inner bay. In summary, although the
54/17	Las Vegas Bay is that when there are more algae, there are
58/9	increased to 1,660 pounds per day. (DEP 25 June 1986.)
59/4-7	<u>Phosphorus Removal Has Cost \$170 Million</u> Phosphorus removal is not cheap. As Figure 25 shows, the equivalent present-day costs so far of building and running the facilities add up to more than \$170 million.
64/18-19	In 1986 the fishery in Las Vegas Bay was as good as or better than it was in 1985 or 1984.
79/22	malfunctions--when it goes into overdrive and gets stuck
82/2	CONCLUSION: Scums result from the buoyant movement of the
85/3	In Panamá's Gatún Lake, the "maximum yearly chlorophyll
87/21	during the <u>Microcystis</u> bloom Paulson (1987) reported for
116/14	DEP asserts that "minimum dissolved oxygen concentrations
124/5	people who use it, than the mere suspicion that ammonia
128/2	in . . . the Clean Water Act, section
128/6	The criteria presented in this publica-

(continued)

<u>Page/Line</u>	<u>Change To:</u>
131/1	value, 304 ug/l, is 760% higher than the proposed standard of
132/7	The lowest observed effect after seven
133/14	concluded that the temperature cap for Lake Mead
136/4	un-ionized ammonia around the clock at station 2 or anywhere
144/18	pull together people from various agencies to exchange

[1 September 1987]

Appendix A

EVALUATION OF PROPOSED STATE OF NEVADA
WATER QUALITY STANDARDS FOR AMMONIA

PRODUCED BY CH2M HILL CALIFORNIA
FOR CLARK COUNTY

EVALUATION OF PROPOSED STATE OF NEVADA
STANDARDS FOR AMMONIA

SUMMARY AND CONCLUSIONS

- No "site-specific toxicity data" exist for Lake Mead waters that would incorporate the life cycle and habitat preferences of the resident organisms. NDEP's limited bioassay work appears to be inconclusive. Standardized laboratory bioassays using Lake Mead water have not been done to establish the site-specific toxicity levels of un-ionized ammonia.
- Limited information exists on the lateral variations in surface-water quality in Las Vegas Bay. Specifically, no data exist regarding lateral variations in total ammonia and total phosphorous concentrations at Stations BC2 and BC3. These data are important in determining complete cross-section dilution values. The protection level established by using center-of-bay concentration data will generally underestimate the near-shore dilution in a plunging plume environment.
- The site-specific procedures for establishing the 0.04 mg/l chronic toxicity level were developed using EPA's standard acute/chronic ratio of 16 for pH ≥ 7.7 . The acute/chronic ratios of the sensitive organisms in Las Vegas Bay, as identified by the Nevada Department of Wildlife (NDOW) and UNLV, suggest that a value of 16 is higher than those values shown for sensitive, resident organisms found in Las Vegas Bay.
- The daytime grab sample data in Las Vegas Bay tends to bias the estimate of continuous temperature and pH and, thus, calculated un-ionized ammonia concentrations toward higher levels. Diurnal variations of temperature and pH can be substantial in the lake surface waters, resulting in considerable diurnal variations in calculated un-ionized ammonia concentrations.
- An application factor of 50 percent is included in the development of the proposed acute level of un-ionized ammonia. The calculated Final Acute Value (FAV) determined by the site-specific procedure is therefore halved in the process of correcting for pH and temperature. This factor is established by the EPA; however, the resultant toxicity at the reduced level of un-ionized ammonia is not clearly defined.

Other concerns remain regarding the present water quality and ammonia toxicity issues in Las Vegas Bay. Ammonia loading was 10 to 20 times more at NSR in 1985 than in 1975 (about 200 lb/day in 1975), and the nutrient loading of total nitrogen in 1985 at NSR was approximately 2 to 3 times greater than in 1975 (about 3,500 lb/day in 1975). The current total phosphorus loads at NSR have been reduced to about 50 percent of those during the mid-1970's due to the advanced waste treatment plant.

RECOMMENDATIONS

A substantial degree of conservatism appears to be incorporated throughout the NDEP water quality standards methodology.

The review, analysis, and evaluation of the water quality standards and procedures by CH2M Hill suggest the following steps should be taken:

1. Obtain additional site-specific bioassay data on the impacts of un-ionized ammonia on sensitive organisms in Las Vegas Bay. Relate these studies to the life cycles of the organisms including where they spawn, are reared, and reside. The studies should be done during the summer period, and water from Lake Mead should be used as the dilution water for the bioassay toxicity tests.
2. The temperature limits used for computing the acute and chronic ammonia toxicity levels for Lake Mead should be adjusted upward to 30°C for acute toxicity and 25°C for chronic toxicity. EPA criteria suggest allowances for this adjustment for site-specific cases with the caveat that the resulting limits must not be significantly different from those tested.
3. The cross-sectional information on total ammonia concentrations should be determined to better estimate the full-width and near-shore dilution.
4. Develop continuous daily average estimates of temperature and pH through summer season diurnal analyses.
5. Data used to represent an average over a time period (daily, monthly, etc.) should be described by more than one or two points in that time period. These data should be supplemented with additional information to support their definition as an average.
6. Incorporate the above information into revised un-ionized ammonia standards in Lake Mead.

BACKGROUND

The NDEP, through its triennial review of water quality standards for Lake Mead and the Las Vegas Wash, has developed revised receiving water quality limits and total maximum daily loads. The current standards do not limit un-ionized ammonia in Lake Mead. Total phosphorus is controlled by a limit of 1.0 mg/l on discharges of effluent (30-day average) for point sources entering Lake Mead (Ref. 30). Pertinent sampling stations are shown in Figure I-1.

The objective of the State's water quality limits is protection of beneficial uses which include fishing and fish habitat, swimming, boating, water supply, and aesthetics. For the summer period, April 1 through September 30, these limits are:

- Un-ionized ammonia (as N) limit = 0.04 mg/l at BC2
- Total phosphorus limit = 1.0 mg/l at NSR
- Total phosphorus goal = 0.05 mg/l at BC3

The present phosphorus concentration limit is a 30-day average of 1 mg/l at NSR. No specific concentration limit has been set for ammonia at NSR; however, a total inorganic nitrogen (ammonia + nitrite + nitrate) limit of less than or equal to 17 mg/l for a single observation is currently in effect (Ref. 30).

BIOASSAYS

Aquatic organisms are exposed to a variety of stresses. It is difficult to isolate just one or a few, even when flow-through bioassay tests are used. Extrapolating laboratory bioassay results to predict or explain isolated environmental perturbations is not always defensible without using site-specific water. This is especially important when evaluating a pollutant, such as un-ionized ammonia which is environmentally reactive. Seasonal and spatial water quality variations in receiving waters compound the problem of making accurate predictions of the target organism's response. In addition, hatchery-reared animals vary in condition, depending on their food and rearing environment (but this can be evaluated by using a standardized toxicant such as DDS). In the field, pollutants can combine with chemicals already present in ambient water and sediment. Therefore, site-specific chemical, physical, and biological information is needed before a specific decision can be made regarding the response of sensitive aquatic organisms to various toxic pollutant levels. Organism lag times in response to environmental stress complicate the problem of predicting effects and can only be properly tracked by systematic monitoring of the target organism.

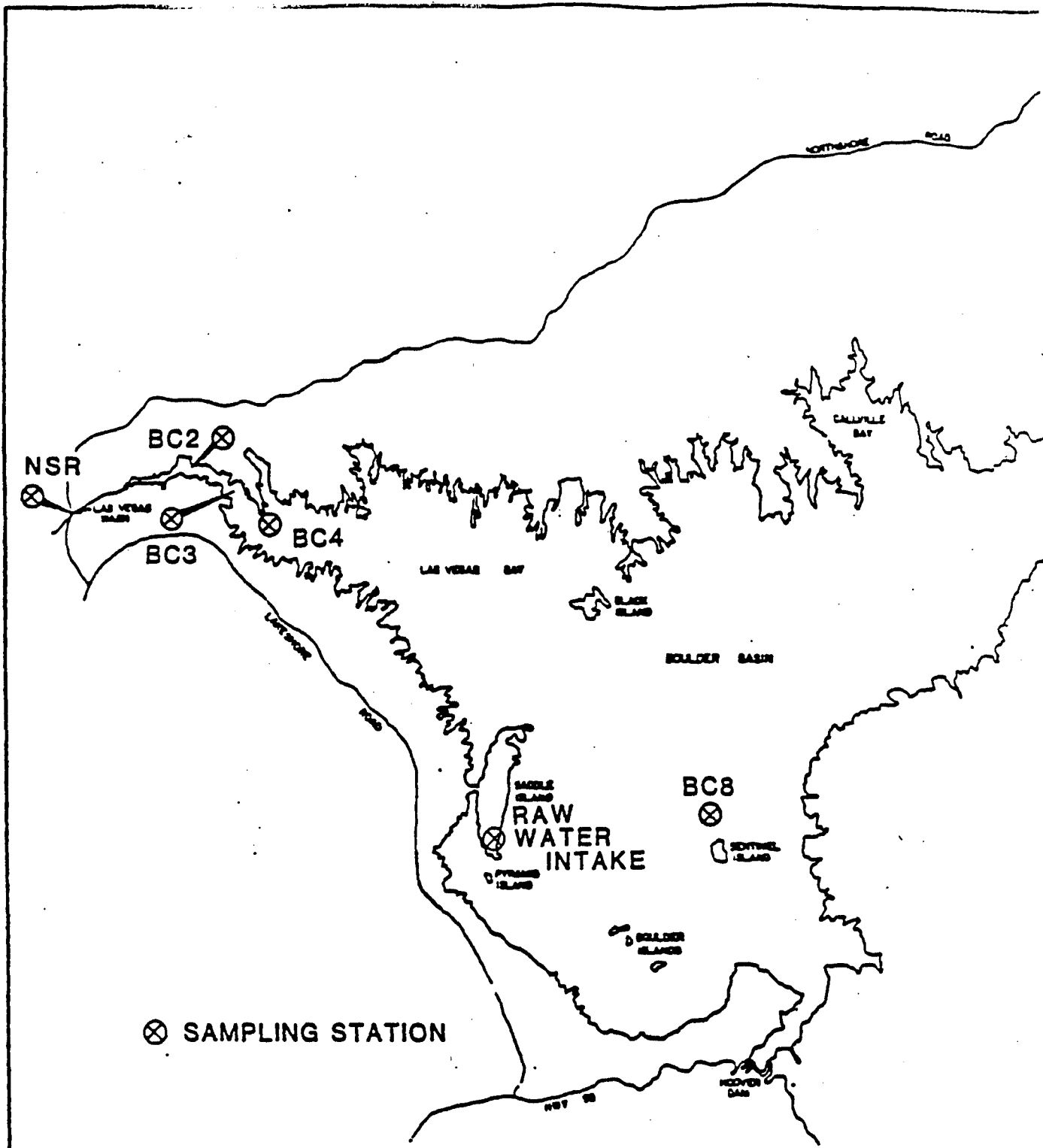

Figure 1 - 1
SAMPLING STATIONS
LAKE MEAD - LAS VEGAS WASH

Monitoring of target organisms can be roughly divided into two categories:

- Observation of individual species of uniform age and size, generally in a controlled environment,
- Observation of communities, generally in a natural environment.

Properly designed bioassays can fall between these extremes, combining the advantages of observation and low-cost inherent in controlled-environment experiments with the obvious advantages of more realistically re-creating the community's ecosystem. Cairns (Ref. 29) developed a seven-point rating system for bioassays:

1. Bioassay organisms must be accurately described.
2. Ambient water quality must be clearly and completely defined.
3. Organisms must be allowed a period of acclimation to the bioassay tank.
4. Test methods and procedures must be clearly stated.
5. Appropriate control organisms must be used.
6. Natural environmental conditions should be accurately reproduced.
7. Data must be evaluated statistically.

Evaluation of chronic toxicity response implies a concern with long-term effects on indigenous aquatic organisms. Subtle differences in growth, reproductive success, feeding success, and behavioral changes reflect natural variation and the lag time between a potential cause of environmental perturbation and its effects. Bioassay results generally tend to imply a greater mortality rate than may truly be the case under natural conditions. In effect, fish are subject to greater stress while undergoing bioassay testing than when they are left in their natural environment.

Using EPA laboratory bioassay results requires the assumption that acute and chronic ammonia toxicities of Las Vegas Bay will be the same as those measured without the use of Lake Mead water. Such an assumption is unsupported by existing data as the NDEP has not conducted laboratory bioassays using Lake Mead water. The in situ bioassay cage tests that were conducted by NDEP were also inconclusive (Ref. 19).

AMMONIA

TOTAL AMMONIA STANDARD DEVELOPMENT

PROPOSED SITE-SPECIFIC STANDARD

EPA water quality criteria were revised by the NDEP to reflect site-specific conditions in Lake Mead. The EPA specifies a method for calculating site-specific water quality criteria (Ref. 9, 10). Through this method, species were ranked according to their sensitivity to toxicants of concern. Final Mean Acute Values (FMAV's) were assigned to 13 vertebrate and invertebrate "resident organisms" inhabiting the study site. Five Lake Mead organisms, including one invertebrate (Cladoceran), were selected as being the most environmentally sensitive to un-ionized ammonia. The organisms and their FMAV's are listed in Table 1.

Table 1
FINAL MEAN ACUTE VALUES (FMAV)
OF UN-IONIZED AMMONIA (Ref. 18)

<u>Organism</u>	<u>FMAV (mg/l as NH₃)</u>	<u>FMAV (mg/l as N)</u>
Largemouth Bass	0.93	0.77
Bluegill Sunfish	1.16	0.96
Green Sunfish	1.16	0.96
Channel Catfish	1.63	1.34
Cladoceran	1.49	1.23

Based on EPA procedures, the acute and chronic ammonia toxicity limits were corrected for site-specific pH and temperature. The acute toxicity level is related to a continuous exposure of 96 hours, and the chronic toxicity level is related to a considerably longer period of exposure (on the order of weeks).

The influence of both pH and temperature on the level of un-ionized ammonia in the water is substantial. Temperature and pH vary diurnally and can cause un-ionized ammonia to fluctuate by a factor of 2.0.

For Lake Mead, the acute toxicity concentration is associated with a single sampled value. The chronic toxicity concentration is related to a 30-day average concentration. The variations of the allowable site-specific concentrations of un-ionized ammonia developed for Lake Mead are shown in Table 1.

Table 2
 SITE-SPECIFIC ALLOWABLE CONCENTRATIONS OF UN-IONIZED AMMONIA (AS N)
 FOR WATERS WITHOUT TROUT (mg/l) (Ref. 18)

pH	Temperature, °C					
	20.0		25.0		30.0	
	Acute	Chronic	Acute	Chronic	Acute	Chronic
7.5	0.24	0.022	0.33	0.022	0.33	0.022
8.0	0.34	0.042	0.48	0.042	0.48	0.042
8.5	0.34	0.042	0.48	0.042	0.48	0.042
9.0	0.34	0.042	0.48	0.042	0.48	0.042

The proposed un-ionized ammonia limits for Lake Mead are for pH of 8.5 and temperatures greater than or equal to 20°C. As defined in Table 2, the acute limit is 0.34 mg/l (as N) and the chronic limit is 0.04 (as N).

The procedures applied in developing water quality criteria for ammonia (Ref. 32) suggest site-specific allowances for adjusting the TCAP (temperature cap) when strictly warm-water species are present. The guidelines caution that the FAV resulting from such an adjustment must not be significantly greater than the acute values (LC50's) at the higher temperatures tested for the most sensitive genera at the site.

Reference 32 suggests that for the species considered by NDEP for Lake Mead where temperature studies have been conducted, the lowest acute value of NH₃-N at 30°C is 1.1 mg/l for the largemouth bass. Using an adjusted TCAP in the FAV procedures of 30°C, the resulting FAV remains the same, 0.48 mg/l NH₃-N, T = 25°C, and pH = 8.0, but would increase to 0.68 mg/l NH₃-N at 30°C. Applying the similar adjustment for TCAP in the Final Chronic Value (FCV) procedures for chronic toxicity to 25°C, the resulting FCV changes to 0.060 mg/l NH₃-N at 25°C.

In review of the summertime temperatures of Lake Mead and the procedures set forth by EPA, the increase of the TCAP by 5°C for both the acute and chronic toxicity procedures is legitimate.

GENERAL EPA AMMONIA STANDARDS

Section 304(a)(1) of the Clean Water Act requires EPA to periodically update "ambient water quality criteria" and to publish its results. The updated information, based on current scientific research, is used to adjust ambient water quality criteria. EPA guidelines (Ref. 9) suggest that freshwater aquatic organisms should not be unduly affected if the ammonia concentration of the water body does not exceed prescribed limits more than once every 3 years. This recommended exceedence schedule is based on the presumption that an unstressed water body will require about 3 years on the average to recover from the exceedence. Because of inherent differences between various ecosystems, site-specific criteria may be established if sufficient data exist to warrant deviations from existing EPA water quality standards.

EPA standards for un-ionized ammonia are summarized in Table 3.

Table 3
EPA GENERAL WATER QUALITY CRITERIA FOR UN-IONIZED AMMONIA (AS N)
FOR WATERS WITHOUT TROUT (mg/l)

pH	Temperature, °C					
	20.0		25.0		30.0	
	<u>Acute</u>	<u>Chronic</u>	<u>Acute</u>	<u>Chronic</u>	<u>Acute</u>	<u>Chronic</u>
7.5	0.15	0.021	0.21	0.021	0.21	0.021
8.0	0.21	0.041	0.30	0.041	0.30	0.041
8.5	0.21	0.041	0.30	0.041	0.30	0.041
9.0	0.21	0.041	0.30	0.041	0.30	0.041

AMMONIA TOXICITY IMPACTS

The dissolution of ammonia in water results in a chemical equilibrium among ionized ammonia (NH₄⁺), un-ionized ammonia (NH₃), and hydroxide ions (OH⁻). The un-ionized form of ammonia is considerably more toxic to aquatic organisms than the ionized form. The proportion of un-ionized ammonia in a water body depends on a combination of available total ammonia, water temperature, pH, and total dissolved solids (TDS).

Receiving waters exert mediating effects on toxicants due to seasonal and diurnal variation in temperature, pH, dissolved oxygen concentration, and dissolved solids composition. Even with an unusually stable effluent, seasonal and diurnal testing is advised to determine whether such temporal, physical, and chemical fluctuations influence potential toxicants.

To date, only one set of in situ cage bioassays has been conducted in the study area. The NDEP conducted these bioassays in Las Vegas Bay and Boulder Basin from October 1 through October 4, 1986. Largemouth bass were used as test organisms. The objective of the study was to determine whether Las Vegas Bay and Boulder Basin waters were toxic to the fish. Largemouth bass mortalities were recorded at Station BC3, below the thermocline (20 meters depth) and above the thermocline (17 meters depth). According to NDEP biologists, the cause of mortalities in both cases was probably due to low dissolved oxygen, which was less than 1.5 mg/l below the thermocline and between 3.5 to 6 mg/l at the 17-meter depth.

DATA REVIEW

The toxic effects of un-ionized ammonia on fish have been thoroughly studied. The information reviewed during the current study was primarily directed toward the site-specific un-ionized ammonia standard(s) as derived by the NDEP (Ref. 18). Other relevant documents (Ref. 3, 4, 5, 9, 11, 12, 13, 15, and 16) were reviewed for their pertinence to the project objectives. Limited information was found on ammonia toxicity to warm-water fish. Most research work appears to have been directed toward cold-water species.

COMMENTS

The procedures used by NDEP in establishing un-ionized ammonia standards in Lake Mead include assumptions that appear compoundingly conservative. As a result, the limits may provide levels of protection beyond site-specific requirements of the Las Vegas Bay.

The following information was used in developing the applicable standards in Lake Mead and serves to illustrate the conservative nature of the methods:

- ° An acute/chronic ratio (A/C) of 16 was applied in the transformation of the FAV to an FCV. This was done by applying EPA's procedures for site-specific evaluation of the sensitive organisms in Lake Mead. The A/C ratios of the five most sensitive organisms shown in the derivation analysis ranged from 3.1 to 12 with an arithmetic average of about 7.2. As a result, the use of the A/C ratio of 16 will mathematically estimate chronic toxicity levels of un-ionized ammonia from laboratory-derived acute levels that are conservative for the five species ranked as the most sensitive in Lake Mead. This process appears to include a safety factor of at least 30 percent greater than the highest A/C ratio of the

- most sensitive species chosen for the site-specific analysis.
- The final acute toxicity criteria as established by EPA procedures for site-specific analysis include an "application factor" of 50 percent which reduces the 96-hour LC50 acute toxicity level actually found in the laboratory tests by a factor of two. The application factor varies between sites and organisms. The toxicity of this resultant FAV is, therefore, not inherently known once the application factor has been introduced.
 - The development of acute levels is typically based on continuous exposure durations of 96 hours. The literature suggests some uncertainty regarding the effect of temporary on intermittent contact on ammonia toxicity. Chronic toxicity levels are typically based on continuous exposures of weeks to months.
 - The un-ionized ammonia standards for Lake Mead/Las Vegas Bay have been established using laboratory bioassay analyses without Lake Mead water. Little data exist on long-term (chronic) toxicity effects on any species of fish (Ref. 11), especially warm-water species.

BIOASSAYS AND TOXICITY

Laboratory conditions for establishing un-ionized ammonia toxicity standards should be similar to receiving water conditions in Las Vegas Bay. To date, no laboratory studies have been conducted using the site-specific Lake Mead water. The cage-type bioassays conducted by NDEP were not conclusive and were adversely affected by other water quality problems.

Bioassay studies should be conducted for at least one and preferably two warm-water seasons before conclusions are drawn as to the effects of un-ionized ammonia concentrations in the receiving waters. Short-term tests do not take the effects of peak and low concentrations of effluent fully into account. Due to these and additional complications previously mentioned, laboratory bioassay tests that do not use site receiving waters are often inadequate indicators of the effects of pollution.

Additional in situ bioassay tests in the inner Las Vegas Bay area are currently being planned by EPA, but the format is presently unknown. We recommend that dischargers be involved in establishing the format of the bioassays and that information on the extent and specific purpose of the tests be made available to all involved parties. Results of such tests are presumably intended to augment laboratory bioassay data accumulated by EPA. Laboratory bioassay results on acute and chronic un-ionized ammonia toxicities to a variety of fish and invertebrates are the basis for EPA toxicity standards. The validity and relative importance of laboratory bioassays, when not augmented by field biological data, have been cause for debate within the scientific community for some time.

To date, no in situ bioassay tests have been conducted by NDEP in shallow Las Vegas Bay shoreline waters adjacent to the plume discharge. It is not clear whether: un-ionized ammonia concentrations are high in these areas, the five most sensitive species are losing shallow water habitat, or some or all of their life stages are being adversely affected. Bioassay information should be obtained in the near-shore environment to define total ammonia levels in those regions of the Bay expected to support sensitive organisms.

Ammonia Toxicity

- Reviewing the historic data at NSR for ammonia loads and relating the number of months of un-ionized ammonia violation (= 0.04 mg/l as N) to the NSR loads provided an indication of the historic assimilative capacity of the Bay.
- The estimation of epilimnetic dilution using center-channel constituent concentrations above the plume will likely result in lower dilution factors than the total dilution factor across the cross section. This provides a substantial measure of conservatism especially since the sensitive organisms selected in the site-specific study generally tend to inhabit the shallow, near-shore waters farthest from the plume.
- Because water temperature and pH are usually greatest during the day water samples are generally taken, the average daily percent of un-ionized ammonia will be conservatively estimated, particularly when compared to standards based on continuous exposure. Continuous monitoring of these dependent variables throughout the day would better describe the daily values to be associated with the total ammonia for computation of the un-ionized fraction.

Las Vegas Wash Nutrient Transformation and Removal Processes

- The historic ratio of total ammonia to total nitrogen at NSR has changed from about 10 percent in 1977 to approximately 80 percent today. The reasons for this change in the characteristics of the total nitrogen at NSR are important to the effect on Las Vegas Bay. Similar loads of total nitrogen at NSR today will contain 10 to 20 times greater amounts of total ammonia.

The changes in the total nitrogen characteristics at NSR are probably due to one or more of the following factors:

- Decreased travel times. The downcutting action of erosion from higher flows and flooding is a normal phenomenon of river morphology. The faster flow through the Wash does not provide as much time for the nitrification process to convert the ammonia to nitrate.

- Reduced area of wetlands. The flooding in the past few years, particularly 1984, reduced the areal extent of the wetlands. This may have served to lessen the treatment capacity in the wetlands.
- Continued nutrient input to the Wash over the years could have caused an overloading of nutrients to the wetlands. This may serve to reduce the efficiency of the nutrient transformation and uptake processes in the wetlands.
- Physical changes, not flood related, in the wetlands, such as the way the water moves through the system, may have reduced the contact area or decreased travel times.

REFERENCES

1. URS Company. Clark County 208. Water Quality Problems in Las Vegas Bay and Boulder Basin of Lake Mead, Water Quality Series. January 1979.
2. Brown and Caldwell, Culp/ Wesner/Culp. Las Vegas Water Quality Program, Draft Report--Water Quality Standards Study, and Appendixes A through F. March 1982.
3. Szumski, D. S., D. A. Barton, H. D. Putnam, and R. C. Polta. Evaluation of EPA Un-ionized Ammonia Toxicity Criteria. Journal WPCF 54(1982):281-91.
4. Meade, J. W. Allowable Ammonia for Fish Culture. Prog. Fish. Cult. 47(3)(1985):135-45.
5. Colt, J. E., and D. A. Armstrong. Nitrogen Toxicity to Crustaceans, Fish and Molluscs. Proceedings of the Bio-Engineering Symposium for Fish Culture, FCS 1, pp. 34-37.
6. Peterson, T. S. Elements of Calculus. Second Edition. Harper and Row Publishers. 1960.
7. Welty, J. R., C. E. Wicks, and R. E. Wilson. Fundamentals of Momentum, Heat and Mass Transfer, John Wiley and Sons, Inc. 1969.
8. CH2M Hill. Considerations in Water Quality-Based Permitting for the City of Boise, Idaho. Draft Technical Memorandum. November 1986.
9. Stephan, C. E., et al. Guidelines for Determining Numerical National Water Quality Criteria for the Protection of Aquatic Organisms and Their Uses. U.S. Environmental Protection Agency, Office of Research and Development.
10. U.S. Environmental Protection Agency. Water Quality Criteria; Availability of Documents. OW-FRL-2871-6, Federal Register, Vol. 50, No. 145 (Monday, July 29, 1985).
11. Willingham, W. T., et al., reviewers. A Review of the EPA Red Book: Quality Criteria for Water--Ammonia. April 1979.
12. Water Quality Criteria for European Freshwater Fish. Report on Ammonia and Inland Fisheries. European Inland Fisheries Advisory Commission, Food and Agriculture Organization of the United Nations, Rome. 1970.

13. Sprague, J. B. Measurement of Pollutant Toxicity to Fish, Part I. Bioassay Methods for Acute Toxicity. Water Research, Pergamon Press, Vol. 3. 1969.
14. Sprague, J. B. Measurement of Pollutant Toxicity to Fish, Part II. Utilizing and Applying Bioassay Results. Water Research. Pergamon Press, Vol. 4, 1970.
15. Sprague, J. B. Critical Review of Measuring Pollutant Toxicity to Fish, Part III (Draft), Sublethal Effects and 'Safe' Concentrations. Fisheries Research Board of Canada. Circa 1971.
16. Ruffier, P. J., William C. Boyle, and James Kleinschmidt. Short-term Acute Bioassays to Evaluate Ammonia Toxicity and Effluent Standards. Journal WPCF 53(1981):367-77.
17. State of Nevada, Department of Environmental Protection. Beneficial Uses, Criteria, Data Manipulation and Procedures for Applying Phosphorus Load Calculations.
18. State of Nevada, Department of Environmental Protection. Derivation of Chronic and Acute Criteria for Un-ionized Ammonia in Lake Mead Waters and Data Manipulations and Procedures for Applying Ammonia Load Calculations. June 1986.
19. Water quality standards correspondence from December 3, 1985 to August 15, 1986, by Clark County Sanitation District, NDEP, Clark County, City of Las Vegas.
20. Skarheim, H. P. Tables of Fractions of Ammonia in the Undissociated Form from pH of 6 to 9, Temperature 0 to 30°C, TDS 0 to 3,000 mg/l and Salinity .5 to 35 g/kg. University of California, Berkeley, SERL, College of Engineering. June 1973.
21. Letters and correspondence between NDEP and Gordon Culp from July 1986 to September 1986.
22. Las Vegas Wash, Water Quality Data at Sites 1, 3, 5 for 1984 to 1986, Clark County Sanitation District.
23. Lake Mead; Physical, Chemical, Chlorophyll-a Data for April-June 1986.
24. Las Vegas Wash and Lake Mead; Physical, Chemical, Biological Data from 1977 to 1985.
25. Letter to City of Las Vegas from NDEP, dated September 8, 1986.

26. Rast, W., R. Anne Jones, and G. Fred Lee. Predictive Capability of U.S. OECD Phosphorus Loading Eutrophication Response Models. Journal WPCF Vol. 55, No. 7.
27. Wetzel, R. G. Limnology. W. B. Saunders and Company. 1975.
28. California Department of Water Resources. Pit River Water Quality. December 1982.
29. Cairns, J. Jr. Fish Bioassays-Reproducibility and Rating. Revista de Biología 7:7-12. 1969.
30. Environmental Reporter, State Water Laws, 841:1070, Lake Mead and Las Vegas Wash, pages 212-216 and 230, 231.
31. Fischer, Hugo B., and R. D. Smith, Observations of Transport to Surface Waters from a Plunging Inflow to Lake Mead, Limnology and Oceanography, 28(s). 1983.
32. U.S. Environmental Protection Agency. Ambient Water Quality Criteria for Ammonia--1984. EPA 440/5-85-001. January 1985.

Appendix B

RESPONSES TO COMMENTS
BY THE NEVADA DIVISION OF ENVIRONMENTAL PROTECTION
ON THE DRAFT FINAL REPORT PREPARED BY CH2M HILL

January 1987

Background

CH2M Hill, under contract to the Clark County Department of Comprehensive Planning, prepared a review of the water-quality standards (WQS) and total-maximum-daily loads (TMDLs) proposed on 25 June 1986 by the Nevada Division of Environmental Protection (DEP). The report is entitled Clark County Water Quality Standards Review, Draft Final Report, and is dated November 1986. On 9 December 1986, DEP sent Mr. Richard B. Holmes, Director of the Clark County Department of Comprehensive Planning, its preliminary comments on the Draft Final Report. This paper responds to several of the issues raised by DEP.

Conclusions

Here are our main conclusions:

1. "Conservatism" cannot justify the proposed WQS and TMDLs.
2. Station 2 data are distorted by location bias.
3. DEP is not legally bound by EPA guidance.
4. Ammonia data are distorted by time bias.
5. The proposed ammonia standard is not reasonable.
6. Assertions about changes in dissolved oxygen are pure speculation.
7. DEP admits that it is using a black-box model -- which is not Brown & Caldwell's deterministic model.
8. The black-box model for Las Vegas Bay is also invalid.
9. Both the deterministic model and the black-box model depend on an assumption that has been proven wrong.
10. DEP's "erosion hypothesis" is incorrect.
11. A new assumption about ammonia and algae is conceptually defective.
12. DEP has not provided a sound scientific foundation or a sound regulatory foundation for its proposals.

1. "Conservatism" Cannot Justify The Proposed WQS And TMDLs.

In its comments, DEP takes two positions on conservatism. First, it argues that conservatism is appropriate:

"Standard engineering practice dictates that in establishing regulations and standards . . . the engineer must be conservative. In the jargon of engineering, the word conservative connotes the use of caution and the tacit admission that our technical knowledge is always limited. Thus, being "non-conservative" would connote a willful disregard of the need to protect public safety and welfare. I would note that this report does not use terminology such as excessive conservatism which might connote wasting money and resources." (Page 1.)

Elsewhere, DEP argues that it has not been conservative. For example:

"We therefore, have no reason to believe that our calculated TMDL's have any level of conservatism." (Page 12.)

There is no dispute that public officials should use caution in setting WQS and TMDLs. There is also no dispute that TMDLs should incorporate a "margin of safety" to protect against variations that cannot be discovered through reasonable investigation.

However, neither conservatism nor a margin of safety excuses mathematical errors, invalid methods, and a refusal to measure what can easily be measured. When DEP uses biased data to calculate a monthly average, it is not being conservative: it is mathematically wrong. When DEP asserts that there is a simple proportion between phosphorus loads at Northshore Road and phosphorus concentrations in Las Vegas Bay, it is not being conservative: it is again mathematically wrong. When DEP uses a deterministic model that is mislabeled, that relies on a farfetched assumption of stability, and that cannot account for wind mixing, secondary plumes, and the other nondilutional processes that control water quality, it is not being conservative: it is being unrealistic. Most importantly, when DEP proposes WQS and TMDLs before conducting a proper study of Las Vegas Bay, it is not being conservative: it is being rash.

The U.S. Environmental Protection Agency (EPA), which is also responsible for protecting the environment and also claims to be conservative, has decided that ammonia removal is not required at all municipal sewage-treatment plants and that ammonia standards are not required for all bodies of water (see 40 CFR §§ 131, 133). EPA has also decided that all WQS must be "based on-sound scientific rationale" (40 CFR

§131.11(a)). This is a regulation, and DEP must follow it. In addition, EPA has strongly suggested that site-specific information should be used for calculating ammonia standards in warm waters like Las Vegas Bay: "Site-specific criteria development is strongly suggested at temperatures above 20°C because of the limited data available to generate the criteria recommendation" (50 Federal Register 30,784, 30,786, 29 July 1985).

In circumstances like these, where there is no evidence of an existing problem and no reason to believe that conditions will deteriorate, the conservative thing to do is to study the problem and draw conclusions from the study. If DEP were truly conservative, it would participate in a study of Las Vegas Bay. After all, there is no reason to guess whether the resident fish are affected by the existing concentrations of unionized ammonia: DEP could easily find out. There is no reason to guess at the magnitude of the time and location biases -- and less reason still to ignore them. Most of all, there is no reason to derive TMDLs from assumptions known to be false.

Good engineering practice, science, public policy, and law -- all require that reasonable investigations should be made before setting WQS and TMDLs. A pollution-control agency cannot cover its eyes and ears and then claim that its proposals are justified by a lack of knowledge.

When DEP issued the existing proposals for WQS and TMDLs -- several months before the time and location biases were discovered -- DEP implicitly represented that, in its judgment, the proposals were properly conservative and included an adequate margin of safety. Since then, the biases have come to light, and it is now clear that the averages, DEP used in its calculations are much higher than the true averages, perhaps by a factor of five or ten. Rather than revising its calculations and adjusting the WQS and TMDLs accordingly, DEP appears to be arguing that it can disregard these errors in the name of conservatism. We do not believe that conservatism gives an agency license to refuse to correct known errors and biases.

Moreover, DEP's "conservatism" is selective. The conservative approach to enhancing the fishery is to eliminate all limits on the discharge of phosphorus, so that the lake can increase its fish production as much as possible. DEP, however, continues to insist on phosphorus restrictions.

Although the proposed WQS and TMDLS will inevitably lead to the expenditure of tens of millions of tax dollars, DEP cannot know whether they will produce any water-quality benefits in return, or whether they -- like

the proposed standards that led to municipal phosphorus removal -- will be an expensive failure. Municipal phosphorus removal in greater Las Vegas is a good example of "wasting money and resources" (DEP's definition of excessive conservatism), and the current proposals are examples of a "disregard of the need to protect public . . . welfare" (part of DEP's definition of non-conservatism).

DEP also uses "conservative" to mean that its proposed TMDLs are not unreasonably restrictive:

"We therefore, have no reason to believe that our calculated TMDL's have any level of conservatism." (page 12)

However, since the data DEP used in its ammonia TMDL are severely biased, DEP's proposed TMDL must be unreasonably restrictive. DEP is not being conservative: it is being unreasonable.

2. Station 2 Data Are Distorted By Location Bias.

CH2M Hill deserves credit for recognizing the location bias: Because the midchannel concentrations are higher than shoreline concentrations, an average computed exclusively from midchannel measurements is much higher than the true cross-sectional average.

DEP asserts that there is no significant location bias (pages 2-3, 4, 8, 10, and 12), and supports this assertion with quotes from the Brown & Caldwell (BC) report. BC, however, was describing Las Vegas Bay in general; it did not mention Inner Las Vegas Bay. Moreover, BC's conclusions were drawn directly from the work of Kellar & Paulson (whose report is included in BC's Appendix B), who did not conclude that there was no significant location bias. They reported that there were differences between the north and south shores of the inner bay, and that ammonia "fluctuated dramatically."

Whether there is lateral variation in most of Las Vegas Bay is irrelevant to the proposed ammonia TMDL, which uses data from only one station in Las Vegas Bay: station 2. The important question is whether there is lateral variation in ammonia concentrations at station 2, and the available data strongly suggest that there are huge variations.

The only work on the lateral variation of ammonia that we have found was done on 6 September 1979 by Kellar & Paulson. They did not publish the data, but it is available from STORET. Ammonia at station 2 was 500-600% higher than at stations C3 and C4, the north-shore and south-shore stations closest to station 2:

TABLE 1

<u>Station</u>	<u>Total Ammoniacal Nitrogen (ug/l)</u>
2 (mid-channel)	37
C3 (north shore)	6
C4 (south shore)	7

At station 3 the variation was nearly 2,000-2,400%:

TABLE 2

<u>Station</u>	<u>Total Ammoniacal Nitrogen (ug/l)</u>
3 (mid-channel)	118
C5 (north shore)	5
C6 (south shore)	6

(Note: All data reported here are from 4.9-meter vertical composites, according to STORET. See Exhibit 1 to this paper for Keller & Paulson's map of station locations.)

These data override BC's general conclusions. There were huge variations in 1979 -- factor-of-six variations at station 2, and factor-of-24 variations at station 3 -- and there is no reason to believe that conditions are any more stable now. Plainly, the location bias in the proposed ammonia TMDL is too great to ignore.

3. DEP Is Not Legally Bound By EPA Guidance.

In several places DEP suggests that it is legally bound by EPA's guidance on ammonia, and that it has no authority to do anything other than what EPA tells it to do. In one context, DEP asserts that "the national guidance requires"; in another, it contends that "this requirement is imposed by EPA . . ., not [by] the State of Nevada" (both on page 6). These suggestions are not legally correct.

There are three questions related to an ammonia standard: (1) whether DEP is required to establish any ammonia standard, (2) whether DEP is required to use the criteria recommended by EPA, and (3) whether DEP is required to use the procedures recommended by EPA. The answer to all three is no.

EPA has not required that ammonia standards be established for every body of water, and the great majority undoubtedly do not have ammonia standards. Ammonia standards are appropriate where they are necessary

to protect a beneficial use, but there is no credible evidence that ammonia standards are necessary to protect any beneficial use in Las Vegas Bay. As we have emphasized in our letters of 17 December and 16 September, mere suspicion is not enough to justify WQS. Consequently, DEP is not required to propose an ammonia standard, and the State of Nevada is not required to establish one.

The answers to the second and third questions turn on the difference between regulations and guidance: Regulations have the force of law, but guidance does not. Because EPA's recommendations on ammonia are in the form of guidance, they are not binding. The guidance document itself clearly says that it is "non-regulatory:"

"The term "water quality criteria" is used in two sections of the Clean Water Act, section 304(a)(1) and section 303(c)(2). The term has a different program impact in each section. In section 304, the term represents a non-regulatory, scientific assessment of ecological effects. The criteria presented in this publication are such scientific assessments. Such water quality criteria associated with specific stream uses when adopted as State water quality standards under section 303 become enforceable maximum acceptable levels of a pollutant in ambient waters. The water quality criteria adopted in the State water quality standards could have the same numerical limits as the criteria developed under section 304. However, in many situations States may want to adjust water quality criteria developed under section 304 to reflect local environmental conditions and human exposure patterns before incorporation into water quality standards. It is not until their adoption as part of the State water quality standards that the criteria become regulatory." EPA (January 1985), Ambient Water Quality Criteria for Ammonia - 1984, page iii (emphasis added).

Nothing in the guidance document is sacrosanct:

"Whenever adequately justified, a national criterion may be replaced by a site-specific criterion, which may include not only site-specific concentrations, but also site-specific durations of averaging periods and site-specific frequencies of allowable exceedances." (Page 6, citations omitted).

Plainly, DEP may propose whatever ammonia standard it pleases, so long as the proposal complies with the EPA regulation that WQS be "based on sound scientific rationale."

4. Ammonia Data Are Distorted By Time Bias.

DEP's response to the reports of time bias is a bare assertion that time bias is irrelevant:

"The information we have suggests that under wide diurnal variations of un-ionized ammonia, growth reductions are better correlated with maximum daily concentrations rather than [with] mean concentrations." (Page 5, also see page 7.)

DEP does not explain this assertion, support it, or provide any references, despite chiding CH2M Hill on page 1 for not providing references. The wording suggests that there are two correlations -- growth reduction versus average daily un-ionized ammonia, and growth reduction versus maximum daily un-ionized ammonia -- but DEP does not provide the scatterplots, the regression lines, or the correlation coefficients. EPA's guidance document does not mention any studies of chronic toxicity in which fluctuating concentrations were compared with steady concentrations of un-ionized ammonia, and we are not aware of any. In short, we have not found any scientific foundation for DEP's assertion.

It is true that Thurston et al. reported that fluctuating concentrations were more likely to be acutely toxic to trout than steady concentrations (Effect of Fluctuating Exposures on the Acute Toxicity of Ammonia to Rainbow Trout (*Salmo gairdneri*) and Cutthroat Trout (*S. clarki*), Water Research 15:911-917 (1981)). However, these results follow from the nature of acute toxicity: It is obvious that someone who drinks a quart of vodka at one sitting is more likely to die from acute alcohol poisoning than someone who drinks one ounce every night for a month. The nature of acute toxicity is different from that of chronic toxicity, and conclusions drawn from tests of acute toxicity should not be inconsiderately applied to chronic toxicity.

DEP's assertion implies that there is no difference between the chronic toxicities caused by (1) fluctuating concentrations and (2) concentrations remaining at or near the maximum. This implication is contrary to the nature of chronic toxicity. The social drinker who takes one cocktail an evening has fluctuating blood-alcohol concentrations -- high in the evening, low the rest of the day. The hopeless alcoholic who drinks all day every day will have blood-alcohol concentrations at or near the maximum all the time. It is obvious that the social drinker is much less likely to suffer from chronic alcohol toxicity than the hardened alcoholic. DEP is surely wrong in suggesting that toxicity is better correlated with a fleeting maximum than with a persistently high average.

We will, of course, carefully review DEP's information as soon as we receive a copy. But even if the assertion were valid, it would still be inconsistent with the proposed ammonia standard and with

DEP's position on EPA guidance. The proposed standard calls for a 30-day average (see DEP's proposal of 25 June 1986, page 4), not for an average of 30 daily maxima. Where there are fluctuating concentrations, there is a great difference between a 30-day average (the average of measurements taken continuously for 30 days) and an average of 30 daily maxima (the average of the daily maxima recorded over 30 days). In some places, where concentrations are steady, a few sporadic measurements may provide a reasonable estimate of the true 30-day average. In places like Inner Las Vegas Bay, however -- where there are large diurnal fluctuations, and where afternoon measurements approach the daily maxima -- an average of a few mid-day measurements cannot provide a reasonable or unbiased estimate of the true 30-day average, and no assertion can change this fact. So long as DEP proposes an ammonia standard that calls for a 30-day average, it cannot ignore time bias.

Although there are many uncertainties about the future, we can confidently predict that the sun will continue to rise in the morning and set in the evening. So long as it does, there will be diurnal variations in un-ionized ammonia. The proposed TMDL should account for them.

5. The Proposed Ammonia Standard Is Not Reasonable.

In order to propose WQS before conducting a proper study of Las Vegas Bay, DEP must make countless assumptions about the fishery, about existing concentrations of ammonia, and about the need for WQS. We believe that many of these assumptions will not withstand scrutiny. In combination, the assumptions have produced what may be called excessive conservatism: a proposal that is not reasonable under the circumstances.

One example of excessive conservatism is the lack of temperature adjustment. It is well known that fish are less sensitive to ammonia toxicity in warmer waters such as those of Las Vegas Bay. For instance, graphs published in the EPA guidance documents, which are attached to this paper as Exhibit 2, show that the three most sensitive fish in Las Vegas Bay -- largemouth bass, bluegill-sunfish, and channel catfish -- are all less sensitive to acute ammonia toxicity at 25-30°C than at 20°C. Nevertheless, DEP has proposed a criterion for water at 20°C, and has failed to adjust it upwards for the warmer waters in Las Vegas Bay. At the workshop on 11 September, Russell Erickson of EPA-Duluth concluded that an adjustment to at least 25°C would be reasonable.

The guidance document warns that the national criteria for chronic toxicity are based on limited data, and strongly recommends site-specific studies in places, such as Las Vegas Bay, where the water is warmer

than 20°C:

"There is limited data on the effect of temperature on chronic toxicity. . . . Because of this uncertainty, additional site-specific information should be developed before these criteria are used in wasteload allocation modeling." (Page 95.)

"Site-specific development is strongly suggested at temperatures above 20°C because of the limited data available to generate the criteria recommendation" (page 97).

Another example of excessive conservatism is the incorporation of the once-in-three-years statistic into the proposed ammonia standard. This statistical requirement allows the criterion to be exceeded only once every three years, on the theory that in three years the biota can "recover from a pollution event in which exposure to ammonia exceeds the criterion" (EPA guidance document, page 98). The statistical requirement appears to be intended for acute criteria, in which a "pollution event" can produce acute toxicity -- that is, dead fish. Death is terminal, but chronic toxicity may have little effect on the population dynamics of the fishery. Consequently, the statistical requirements for chronic criteria should be adjusted accordingly. EPA has no objection to appropriate adjustments: "The resilience of ecosystems and their ability to recover vary greatly, however, and site-specific criteria may be established if adequate justification is provided" (guidance document, page 98).

In order to comply with the once-in-three-years requirement, average conditions in Las Vegas Bay would have to be far below the criterion, which in turn would be far below the actual chronic-toxicity level (owing to the margin of safety). The result is a second margin of safety -- which is not required by regulation, and which does not appear to be warranted under the circumstances. Consequently, a criterion intended to prevent chronic toxicity ought to incorporate a more reasonable statistical requirement. Perhaps it should be phrased in terms of average conditions.

But why have any ammonia standard at all? DEP's key assumption is that existing concentrations of un-ionized ammonia are harming the fishery in Las Vegas Bay. However, as the Nevada Department of Wildlife reported at the workshop on 11 September 1986, there is no evidence of harm to the fishery. The only available evidence is that Las Vegas Bay has the best fishery in Lake Mead, and that -- judging by where the fishermen are -- Inner Las Vegas Bay has the best fishery of all.

DEP has said that it is particularly concerned with threadfin shad,

which is reported to be the primary source of food for the game fish in Las Vegas Bay. Owing to the lack of a proper study, DEP has had to make assumptions about threadfin shad:

"Because no literature exists on the toxicity of ammonia to threadfin shad, we must assume they are as sensitive as largemouth bass, the most sensitive species [in Las Vegas Bay]." (Page 5.)

This assumption leads to an obvious question: Before establishing standards that may result in wasted money and resources on the order of tens of millions of dollars, why not find out how sensitive threadfin shad are?

Even if DEP's assumption is correct, and threadfin shad are as sensitive as largemouth bass, there are still not sufficient grounds to establish an ammonia standard. After all, there is no evidence of harm to largemouth bass or to any other fish. In order to conclude that the sensitivity of threadfin shad results in harm to the sport fishery, DEP must make two additional assumptions: that existing concentrations of un-ionized ammonia harm the threadfin shad in Las Vegas Bay, and that harm to the threadfin shad causes harm to the sport fishery. There is no evidence to support either of these assumptions. In fact, there is no credible evidence that the true 30-day cross-sectional average has ever exceeded the proposed 40 ug/l standard, much less the true chronic-toxicity level. When DEP implies, as it did on page 11 of the 9 December letter, that the 1985 "all 6 months from April through September" exceeded the proposed ammonia standard, it is mathematically wrong.

In short, the proposed ammonia standard rests only on a foundation of assumptions, and is not supported by any empirical evidence of harm. DEP has assumed both the problem (chronic toxicity) and the cause (un-ionized ammonia). Under the circumstances, there is no reason why DEP should not postpone any ammonia standard until it has completed a proper study of chronic toxicity in Las Vegas Bay and evaluated the results of the study. When the truth can be easily ascertained, we do not believe that it is reasonable to derive a standard from unsupported assumptions.

6. Assertions About Changes In Dissolved Oxygen Are Pure Speculation.

When CH2M Hill speculated that increases in the ammonia load have decreased the concentrations of dissolved oxygen (DO) in Las Vegas Bay, DEP was quick to agree (pages 5 and 12). However, DEP has never produced any trend analysis showing that DO is lower now than it was in the past, and we are not aware of any analysis of DO trends. Once

again, DEP is resorting to assumption and speculation rather than facts -- in this case, readily available facts.

Low metalimnetic DO concentrations are characteristic of reservoirs in the Colorado River Basin, including Lake Powell and Flaming Gorge Reservoir, even though these reservoirs are upriver of all significant wastewater discharges. Metalimnetic DO depression has been reported in Lake Mead since 1964 and has been documented at locations unaffected by Las Vegas Wash. UNLV's monitoring program has documented low DO concentrations in the 1980's in such locations as Grand Wash and Fish Island - locations never receiving water from Las Vegas Wash. Because ammonia loading in Las Vegas Bay cannot possibly affect most of the lake, there must be some other explanation of the phenomenon, and current hypotheses suggest that respiration and detritus are the main causes. Since Las Vegas Bay is the most productive part of Lake Mead, it would naturally have the greatest respiration and detritus, and also the greatest metalimnetic DO depression. The productivity of the bay, of course, is what makes it the best fishery in the lake, and no one has shown that DO concentrations can be increased without harming the fishery.

Until there has been a showing that (1) DO concentrations are worse now than they were in the past, and (2) the change is attributable to increases in ammonia loading, any talk of an ammonia-DO connection is pure speculation. Although speculation may be appropriate from a consultant working within a tight budget, it is not an appropriate justification for an ammonia standard.

7. DEP Admits That It Is Using A Black-Box Model -- Which Is Not Brown & Caldwell's Deterministic Model.

For the first time, DEP has described its modeling as "'black box' empirical modeling" (Page 10). This is a major change. Until now, DEP has insisted that it was using Brown & Caldwell's deterministic dilution-ration model, attached as Exhibit 3 to this paper. Although the two kinds of models share the same formula, they depend on entirely different conceptual schemes. Here is the conceptual scheme for a black-box model for Las Vegas Bay:

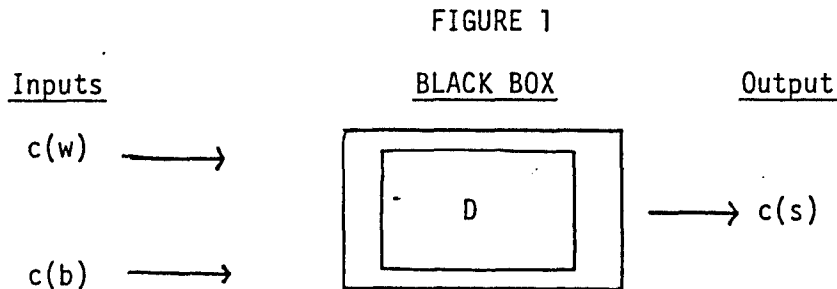

Where $c(w)$ is the concentration at Northshore Road
 $c(b)$ is the background concentration
 $c(s)$ is the concentration at station "s"
 D is the black-box formula

Unlike the deterministic model, which assumes that the relations among $c(w)$, $c(s)$, and $c(b)$ are completely determined by the model, the black-box model makes no assumptions about the relations. Whatever processes control the outcome take place in the opaque "black box" that gives the model its name. The black-box formula is not assumed to represent anything realistic; it is merely a mathematical means of transforming the inputs into the output.

Although DEP does not explicitly say so, the switch to black-box modeling may be a recognition of the defects in Brown & Caldwell's deterministic model. In order to defend the deterministic model, DEP has had to take increasingly unrealistic positions. There are at least four fundamental defects in the deterministic model, any one of which invalidates it:

(a) The diagram is wrong. The conceptual diagram underlying Brown & Caldwell's model is simply not an accurate picture of Las Vegas Bay. Brown & Caldwell's dye study in 1980 clearly showed that the water is not divided into two distinct volumes separated by a clear interface; it showed that there was no clear interface, that there were strong secondary plumes, and that the plume was very unstable. (See our letter of 8 August 1986 and the accompanying paper, and Fischer & Smith (1983), Observations of transport to surface waters from a plunging inflow to Lake Mead, Limnol. Oceanogr. 28 (2):258-272.)

(b) The labeling is wrong. In Brown & Caldwell's diagram, the plume or hypolimnetic concentration at station "s" -- which should be labeled $c(sh)$ -- is labeled $c(w)$, the concentration at Las Vegas Wash at Northshore Road. But the concentration in the plume is never the same as the concentration at Northshore Road, no matter what substance or station. As DEP admitted in its letter of 8 September 1986, the plume concentration is some function of the concentration at Northshore Road and of other, unidentified variables, but this function is unknown.

(c) The assumption about advection is wrong. Brown & Caldwell assumed that advection was the only force that mixed water from the plume into the surface waters. It is now clear that this assumption is wrong, and that wind mixing -- a force entirely overlooked in the model -- is much more important. (See our letter of 17 December 1986, as well as Fisher & Smith).

(d) The assumption of stability is farfetched. Dr. Douglas Selby of the Clark County Sanitation District was the first to point out that the model depends on an unreasonable assumption

about stability (see his letter of 24 June 1986). In its letters of 15 August and 8 September 1986, DEP replied that its assumption of stability was somewhat different from Selby's -- it assumed that the average rate of change (and also the total rate of change) of the "epilimnetic mass" was zero. (The "epilimnetic mass" is the concentration in the upper volume, which is incorrectly assumed to be uniform, times the epilimnetic volume.) DEP has not provided any justification for this assumption.

We believe that DEP's reply does not cure Dr. Selby's objection -- that it is improper to assume that Las Vegas Bay is stable. There are several reasons why DEP's assumption of stability should be rejected. First, it cannot be tested. Because the distinct boundary required by the model often does not exist, there is often no way to calculate the "epilimnetic mass," and consequently no way to determine whether it is stable.

Second, for DEP's assumption to be true, there must not be any trends in "epilimnetic mass" during the averaging period. But there is good reason to believe that there are trends in "epilimnetic mass," since there are known trends in un-ionized ammonia (highest in spring), in chlorophyll (higher in summer than in the fall), in epilimnetic volume (owing to the rise and fall of the thermocline), in lake level (owing to reservoir regulation), and in temperature. Over the years there have also been trends at Northshore Road (in ammonia, phosphorus, and conductance), at the lake stations (in ammonia, chlorophyll, and conductance) and at background (in ammonia and conductance). With all these known trends, it is not reasonable to assume that there are no trends in "epilimnetic mass" -- a concept often unrelated to anything measurable in Lake Mead.

Third, the assumption of stability is not supported by existing data. Given the extreme hourly fluctuations that were documented during the 1980 dye study, it is unreasonable to assume that there is monthly or seasonal stability.

Finally, even if the assumption were true, there would be a large error created by the difference between the true average and the average calculated from the few measurements taken. DEP has not compensated for this error, or even considered it.

If DEP has abandoned Brown & Caldwell's deterministic model in favor of a black-box model, these criticisms of the deterministic model become irrelevant.

The switch to black-box modeling would also simplify some of the existing debate about modeling. We have no quarrel with the argument that a verified black-box model "obviates the need for the inclusion of travel times, detailed environmental measurements, and a comprehensive knowledge of plume dynamics," as DEP claims in its letter of 8 September 1986 -- but the black-box model for Las Vegas Bay cannot be verified, as we will show. The switch to black-box modeling also vitiates all claims that the model "has a basis in physical reality (i.e., the laws of continuity and conservation of mass)," as DEP asserted in its letter of 2 October 1986.

The switch, however, would have no effect on DEP's claim that the "dilution ratio itself takes into account physical, chemical, and biological changes to a given constituent," also from the letter of 2 October 1986. Neither the deterministic model nor the black-box model has any term for chemical or biological transformations, or for any physical process besides advection. The models do not take physical, chemical, and biological processes into account: they ignore them.

8. The Black-Box Model For Las Vegas Bay Is Also Invalid.

The key requirement of a black-box model is consistency: A given set of inputs must consistently produce one output. So long as there is consistency, the model can predict the output for a given set of inputs. But if there is no consistency -- if one set of inputs can produce many outputs -- the model has no way to choose among the possibilities, and consequently it cannot reliably predict the output.

The rule is simple: Consistent relationships are predictable; inconsistent ones are not. When there are consistent relationships in a set of data, competent statisticians can identify them and set limits on the accuracy of predictions from the data. But when the relationships are clearly and unquestionably inconsistent, accurate predictions are impossible.

The data show that Las Vegas Bay is far too inconsistent for black-box modeling. Take ammoniacal nitrogen at station 2, for example. According to DEP's calculations, the monthly average of the black-box-formula D has varied from 8 to 1,694 -- a factor of 200 -- during the 36 months included in the proposed TMDL (see DEP's printout dated 19 March 1986). So long as D varies by a factor of 200, the output must also vary by a factor of 200. Consequently, the black-box model cannot determine whether an output will be a trivial 5 ug/l or a substantial 1,000 ug/l. Bear in mind that these are monthly averages; the variation among daily averages must be even larger.

Because a black-box model cannot explain anything, the one test of its validity is how well it predicts. The test of predictive ability is verification, a procedure in which a model is compared against a data set independent of those data from which the model was built and calibrated. A model that fails its verification test cannot be expected to predict the future. On inspection, the black-box models for both ammonia and phosphorus are seen to be predictive failures.

The failure of the black-box model for phosphorus has already been proven beyond a reasonable doubt. Brown & Caldwell, using data from 1979-1980, failed to predict D for 1981-1985; BC was off by a factor of three (see CH2M Hill's draft final report, table III-1 on page III-5). As a result, the municipal phosphorus removal on which Las Vegas and Clark County have spent approximately \$100 million failed to produce any of the predicted benefits.

Undeterred by BC's failure, DEP produced precise predictions of future Ds for phosphorus -- 14.0 for station 2, 25.8 for station 3, 72.8 for station 4, and 125.0 for station 5 -- based on average conditions during 1981-1985 (DEP's proposed TMDL for phosphorus, June 25, 1986). Conditions during 1981-1985, however, were not good predictors of conditions during 1986, in which there was a sudden and substantial increase in chlorophyll unaccompanied by a corresponding increase in phosphorus loading. Although the preliminary data have not yet been analyzed, they will inevitably prove that DEP's predictions were wrong.

The black-box model for ammonia, had it been used in the past, would also have been a failure. In particular, it would have failed to predict the unexpected events of 1985, when D plummeted and concentrations in the lake increased sharply (see DEP figures reproduced as Exhibits 4 and 5 to this paper).

What will happen in 1987 is anyone's guess. The behavior of both ammonia and phosphorus is too inconsistent for black-box modeling, and no one knows enough about the nondilutional processes that control water quality in Las Vegas Bay to build an adequate deterministic model.

9. Both the Deterministic Model and the Black-Box Model Depend on an Assumption That Has Been Proven Wrong.

Both models, as well as both of the proposed TMDLs, depend on the assumption that any change in concentration or load at Northshore Road will result in a proportionate change in concentration at station 2. This is precisely the assumption that was proven wrong by the

\$100 million expenditure for municipal phosphorus removal: Despite an 80-90% decrease in phosphorus loading, there has been no improvement in phosphorus concentrations or chlorophyll at station 2 or anywhere else in the lake. This evidence proves beyond any doubt that simple proportions cannot accurately predict how changes in phosphorus loading might affect water quality in the lake.

DEP's commitment to the assumption of proportionality was reaffirmed on page 8 of its letter of 9 December 1986, where it used its "direct proportion" method on biased ammonia data (without attempting to correct for the bias). DEP has never tried to demonstrate that the assumption of proportionality is any more appropriate for ammonia than it is for phosphorus, and there is reason to believe that the assumption is false. Nondilutional processes are primarily responsible for the decrease in ammonia concentrations between Northshore Road and station 2 (see our letter of 20 October 1986 and the accompanying paper, especially pages 4-8; also see below). Although these nondilutional processes have never been carefully studied, they are likely to be biological, and it is not reasonable to assume that biological processes will remain unaffected by drastic changes in loading. After all, Las Vegas Wash is the predominant source of food and nutrients for most of the biota at station 2, and drastic changes in food supply are likely to affect the ecology.

10. DEP's "Erosion Hypothesis" Is Incorrect.

In order to explain the recent history of water quality in Las Vegas Bay, DEP has advanced what may be called the "erosion hypothesis" because it depends largely on assumptions about erosion. Here are the key assumptions:

- * temperature has increased in Las Vegas Wash because of erosion, which has changed the cross-sectional profile and created a delta at the bay,
- * leakage from the plume has increased because of decreased density of the water in Las Vegas Wash; this decrease is attributable to increased temperature and decreased conductance, and
- * the ammonia load has increased because of destruction of the wetlands by erosion (see DEP letter of 9 December 1986, page 11).

These assumptions are demonstrably false or highly suspect for the following reasons: (1) there is no trend in the temperature of Las

Vegas Wash at Northshore Road, (2) there is no trend in leakage from the plume, and (3) it is unlikely that the wetlands removed much ammonia.

Temperature data for Las Vegas Wash at Northshore Road come from four sources: USGS, Clark County Sanitation District (CCSD), the University of Nevada (UNLV), and Brown & Caldwell (BC). Of these four, only USGS has collected temperature data from 1979 through 1985. BC managed data during 1979-1980 (although UNLV actually did the sampling), UNLV collected data during 1981-1983, and CCSD collected data during 1984-1985. When USGS data are analyzed alone, they show a very small range of April-September averages -- a mere 1.3°C -- and no trend. The same conclusions hold true for each of the other sources.

However, UNLV data are consistently about 4°C higher than USGS data, and CCSD data are consistently about 6°C higher. Because of the addition of UNLV data in 1981, and especially of CCSD data in 1984, the appearance of a trend can be created by pooling the data. This pooling is illegitimate. The apparent trend is an artifact of the unequal pooling. When this bias is corrected by separating the data for each agency, the data show no temperature trend.

As we explained in our letter of 20 October 1986 and the accompanying paper, conductance is not substantially affected by sedimentational, biological, and the other nondilutional processes likely in Lake Mead (page 5). Consequently, the dilution ratios for conductance calculated by DEP can be used as an estimate of dilution. If dilution were the only process affecting ammonia, the so-called "dilution ratios" for ammonia would be identical to those for conductance, but they never are. The "dilution ratios" for ammonia estimate dilution plus nondilutional processes, which undoubtedly include nitrification and algal uptake. Consequently, one can obtain an estimate of the nondilutional processes by subtracting the estimate of dilution (i.e. the dilution ratio for conductance) from the "dilution ratio" for ammonia. The difference may be called the "nondilution ratio."

In our letter of 20 October 1986 and the accompanying paper, we provided July-September averages (in keeping with DEP's early methods). Here are the April-September averages at station 2 for conductance, for ammonia, and for nondilutional processes affecting ammonia:

TABLE 3

1 Year	2 TAN*	3 Cond (DP)**	4 TAN - Cond (NDP)***	5 NDP/TAN
1979	129.5	21.5	108.0	83%
1980	132.3	16.9	115.4	87%
1981	79.2	10.7	68.5	86%
1982	90.7	14.2	76.5	84%
1983	408.8	16.2	392.6	96%
1985	20.7	9.0	11.7	57%

- * Total Ammoniacal Nitrogen
- ** Estimate of dilutional processes
- *** Estimate of nondilutional processes

(From DEP printout dated 15:20 Wednesday, 19 March 1986. We have deleted the conductance dilution ratio for September 1983, which is negative and cannot be correct.)

Two major conclusions can be drawn from this table:

* There is no consistent trend in leakage from the plume, as estimated by the dilution ratios for conductance. (When reviewing column three, bear in mind that a higher number implies that there was relatively less leakage, and vice versa.) Leakage appears to have increased until 1981, decreased until 1983, and increased again in 1985.

* Nondilutional effects overwhelm dilutional effects. For example, the increase in leakage that may have taken place between 1983 and 1985 (nearly a factor of two decrease in dilution) was trivial compared with the change in nondilutional processes (equivalent to a factor of 33 decrease in dilution). See column 4.

The wetlands in Las Vegas Wash were never very large; there were approximately 150 acres just above Pabco Road and 100 acres just below (U.S. Bureau of Reclamation (25 September 1979; date corrected to 22 August 1975 in marked print (23 September 1986) by Art Tuma, U.S. Bureau of Reclamation, Boulder City. Phreatophytes along Las Vegas Wash. Three sheets, each 21" x 36", numbered 1297-300-140 through 1297-300-142). A wetlands area of this size would have been able to provide treatment to only a few million gallons a day, at best, but flows in Las Vegas Wash have been above about 55 mgd for nearly a decade. Plainly, the wetlands

could have provided only limited treatment. Another problem with DEP's assumption is that the ammonia loads in Las Vegas Wash did not increase immediately after the wetlands were destroyed in 1984; there was a gap of several months. The small size of the wetlands, in combination with the time gap between their destruction and the increase in ammonia loading, suggest that the loss of the wetlands did not cause the increase in ammonia loading.

We understand that the available data show that most of the ammonia removal took place in the muddy, turbulent, well-aerated stream between the wetlands and Northshore Road, and that nitrifying bacteria may have been responsible (See, for example, Figures 6-12 and 6-35 in BC's 1982 Draft Report). This hypothesis ought to be investigated. Until it is, there is unlikely to be a sound scientific explanation for the increase in ammonia loading that began at the end of 1984.

It is not clear whether DEP attributes the apparent increase in ammonia loading during 1976-1978 to erosion. CH2M Hill reports that the ammonia load increased by a factor of ten -- from 230 pounds per day to 2,300 pounds per day -- during that interval. Although the headcut may have moved 0.5 mile during that time (see Exhibit 6 to this paper, which we have prepared), we know of nothing in the affected stretch that could possibly account for a factor-of-ten increase. Another hypothesis is that the increase is attributable to improvements in sampling and analysis; ammonia analyses run on stale samples are notoriously low. If the data collected before 1978 are falsely low, then the following DEP assertions are also false: the proposed ammonia TMDL "was met in all years prior to 1978" and "is over 7 times higher than the 1974 total ammonia load," and the "current total ammonia load is nearly 30 times the 1974 load" (letter of 9 December 1986, pages 11-12).

11. A New Assertion About Ammonia And Algae Is Conceptually Defective.

For the first time, DEP has repeated an argument made by Larry Paulson at the ammonia workshop on 11 September 1986: "Controlling ammonia toxicity will have the side-benefit of reducing the probability of a blue-green algae bloom . . ." (page 10). DEP attributes this argument to suggestions "by some," however, and does not clearly adopt this argument as its own. If it were to adopt this argument, DEP would be radically departing from all its earlier claims that phosphorus -- not ammonia -- controls algal growth in Las Vegas Bay.

Although Dr. Paulson has been making this argument for some time, he has not yet provided any data analysis, written explanation, or

documentation of any sort to support the argument or to dispel the obvious conceptual flaw. Many algae, including Microcystis, can satisfy their nitrogen requirements with ammonia or nitrate; either one will do fine. Nitrate concentrations in Las Vegas Bay exceed 1,000 ug/l as N at station 2 and are often over 200 ug/l even at station 5. Nitrate concentrations of this magnitude could support a huge Microcystis bloom even if there were no ammonia in the lake. Until Dr. Paulson finds a solution this conceptual defect, we see no reason to take his arguments seriously, and we have interpreted DEP's silence as a sign that it feels the same way.

Although DEP asserted that ammonia control "will" reduce "the probability of a blue-green algae bloom," we doubt that it intended to be so certain and statistically precise. The probability of a blue-green bloom is near 100% -- most of Lake Mead is dominated by blue-green algae every summer -- and ammonia control, which cannot possibly affect most of the lake, cannot reduce the probability. The probability of a Microcystis bloom is another issue, of course, but no one knows enough to calculate the probability of a Microcystis bloom, much less the difference in probabilities with and without ammonia control. DEP undoubtedly intended to say something like this: If Larry Paulson turns out to be right, so much the better. A sound scientific foundation for regulatory decisions is not built on hopes and speculations.

12. DEP Has not Provided A Sound Scientific Foundation Or A Sound Regulatory Foundation For Its Proposals.

DEP's proposals for a phosphorus standard and a phosphorus TMDL fill about 2½ pages of explanatory text. The proposals for an ammonia standard and an ammonia TMDL fill about 4½ pages of explanatory text. To be sure, DEP has distributed quite a few pages of raw data and computer printouts, and a few charts and diagrams -- the kind of documentation appropriately included in appendices to a main report. The problem here is that there is no main report.

DEP's few pages of text are hardly enough to explain anything. They are devoted mostly to an overview of the TMDL methods, but the text does not clearly explain the methods. As a result, we have had to write many letters and spend a great deal of time and effort just to understand, more or less, what the methods actually were. There are still large gaps in DEP's proposals. For example, DEP has never released the full text of any proposed standard, and has never adequately explained its phosphorus standard (see our letter of 14 November 1986).

The proposals say virtually nothing about the major scientific issues, including underlying assumptions on which the WQS and TMDLs are based, evidence supporting these assumptions, other hypotheses that might explain the data, evidence refuting these hypotheses, unknowns and

gaps in available data, unexplained inconsistencies between STORET files and UNLV's computerized data base (which has yet to be corrected and delivered to us, despite six months of requests and correspondence), and conclusions that can reasonably be drawn from the existing evidence. Furthermore, the proposals say nothing about the range of regulatory choices available, the pros and cons of each choice, and why DEP chose the course of action it did. In short, DEP has not produced an adequate scientific document that can be subjected to peer review, and it has not produced an adequate regulatory document that explains its decision.

As a result, we have had to write a series of letters to ask for more information, to share our discoveries (as we found them) about the methods and the data, and to respond to questions and comments from DEP. Although DEP has written many letters since its proposals, all its letters taken together neither cure nor attempt to cure the basic deficiencies set out in the paragraph above.

Instead, DEP's letters routinely introduce assertions that are unsupported by any evidence. For example, the letter of 9 December 1986 asserts that "increasing the productivity further out into the bay will have a detrimental and unacceptable effect on the operation of the Southern Nevada Water System," which supplies drinking water to Greater Las Vegas. DEP has never produced any evidence to show that there is any relationship between productivity in the lake and operation of the Southern Nevada Water System. Like many others, this claim is pure speculation.

In addition, the letters sometimes introduce confusion where the record was clear. DEP's proposal of 25 June 1986 clearly specifies a phosphorus TMDL of 692 pounds per day (page 3), but DEP's letter of 9 December 1986 insists that the proposal is for 637 pounds per day (page 2). In its letter of 24 October 1986, DEP raised the proposed ammonia TMDL from 1660 to 1698 pounds per day, but in its letter of December 9, 1986 it says that the recommendation is for 1660 pounds per day (page 9).

The lack of an adequate scientific and regulatory report has made it difficult to determine what DEP's proposals actually are, whether they are reasonable under the circumstances, and whether there are better scientific explanations and regulatory actions. We believe that it would not be in the public interest to commit tens of millions of dollars to decisions based on the existing hodgepodge. Without an adequate explanation from DEP, we can only conclude that the existing proposals are based on biased data, pure speculation, and assumptions that have been proven wrong.

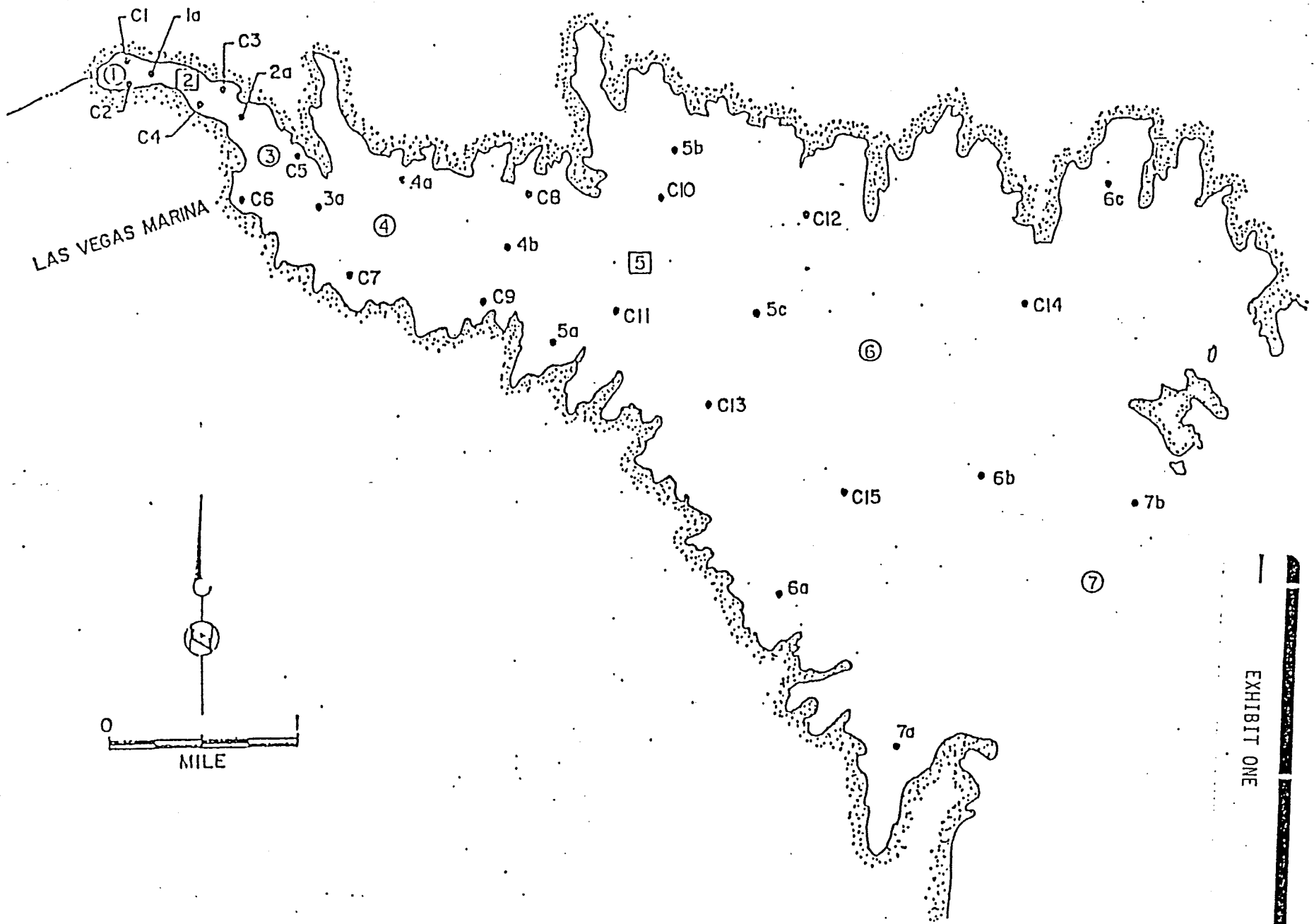

Intensive Survey Sampling Station Locations

EXHIBIT ONE

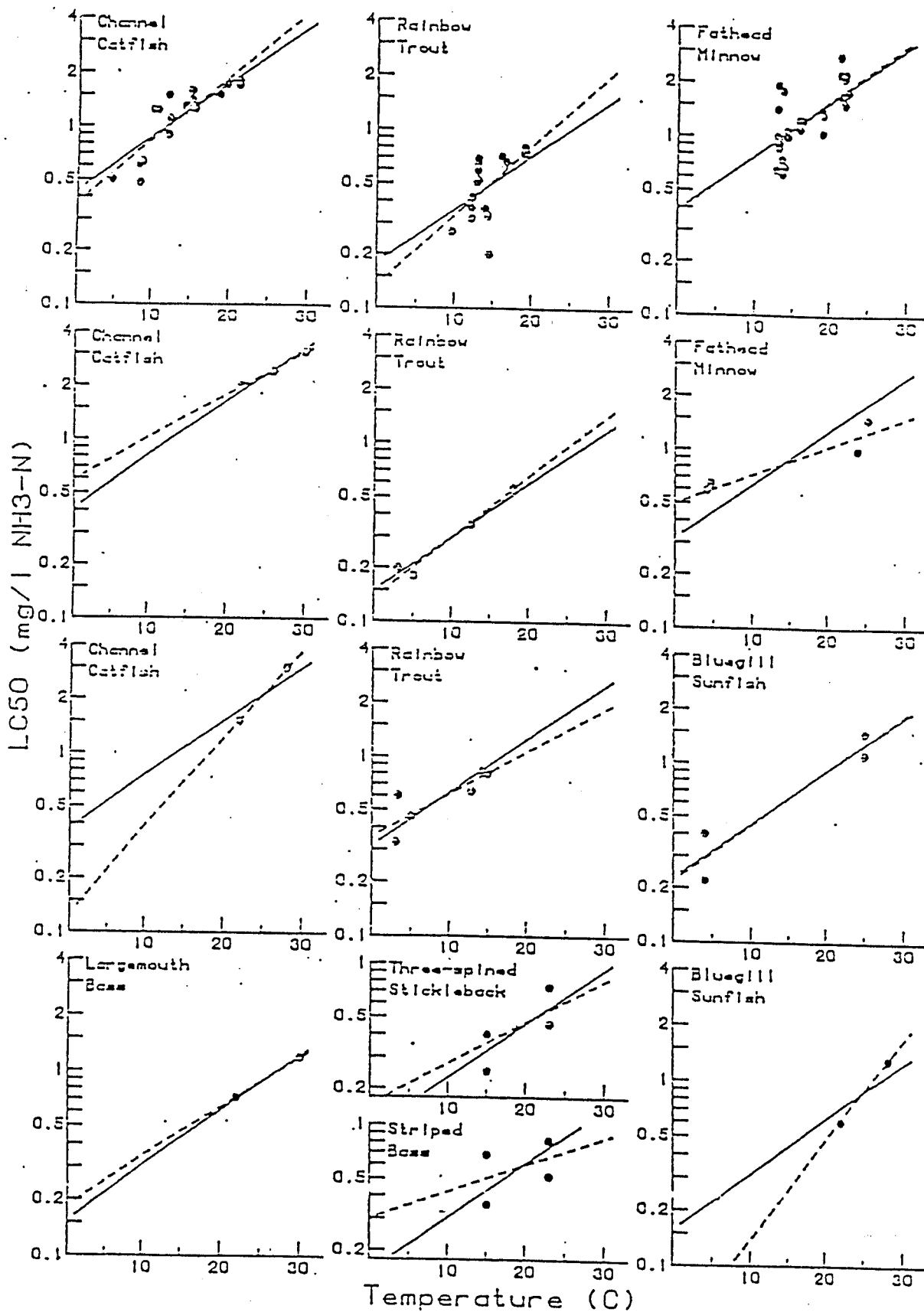

EXHIBIT TWO

Figure 2. Acute NH_3 toxicity at different temperatures (data from Cary 1976, Thurston and Russo 1983, Thurston et al. 1983, Colt and Tchobanoulous 1976, Ministry of Technology 1968, Reinbold and Pescitelli 1982, Roseboom and Richey 1977, Hazel et al. 1971). Dashed lines indicate individual regressions; solid lines indicate pooled regression.

Material balances can be applied to each segment of the bay to develop desired wash-surface concentration relationships. The result for Segment 1-2 comparable to equation (4) is:

$$c_{m2}/Q_w = \frac{(c_w - c_{p1})}{(c_{p1} - c_1)} \frac{(c_1 - c_2)}{(c_{p2} - c_2)} - \left[1 + \frac{(c_w - c_{p1})}{(c_{p1} - c_1)} \right] \frac{(c_{p1} - c_{p2})}{(c_{p1} - c_1)} + \frac{(c_w - c_{p1})}{(c_{p1} - c_{p2})} \frac{(c_{p2} - c_1)}{(c_{p2} - c_2)} \frac{(c_2 - c_2)}{(c_{p2} - c_2)} \quad (5)$$

Equation (5) indicates the increasing complexity of the relationship between wash and surface concentrations with increasing distance from the wash.

Simplified Dilution Calculations--Simplification of the detailed mass balance approach described above was required for practical application. A simplified schematic description of a typical bay segment, Figure 8-53, was developed. Basic features of the system are retained. Inward surface flow, Q_s , originates from the background region at, Q_b , where the concentration is c_b . The high input concentration, c_w , is mixed from below at a low rate, Q_m .

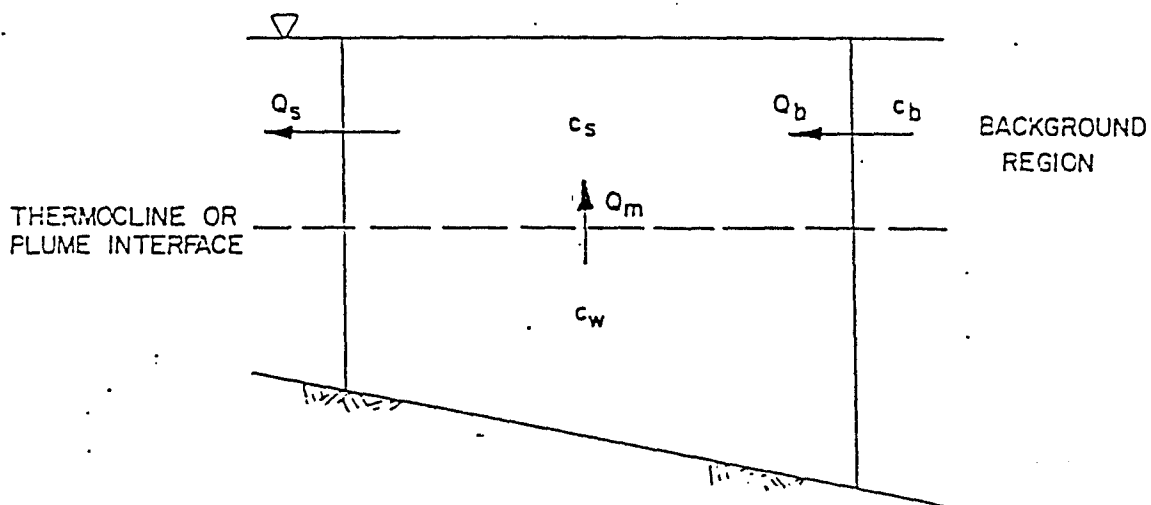

Figure 8-53 Simplified Bay Surface Layer Dilution Schematic

TOTAL AMMONIA — MG/L

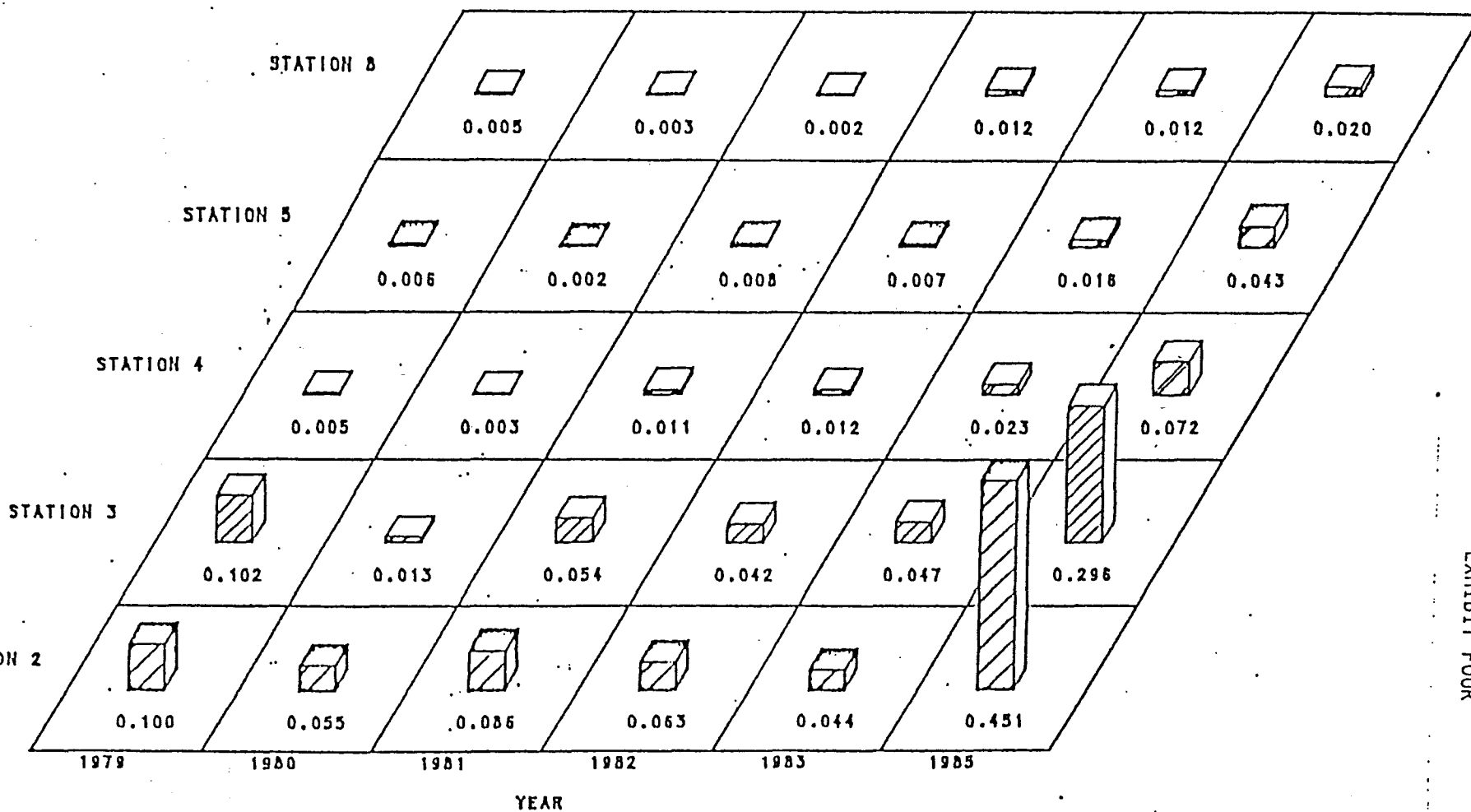

EXHIBIT FOUR

UN-IONIZED AMMONIA - MG/L

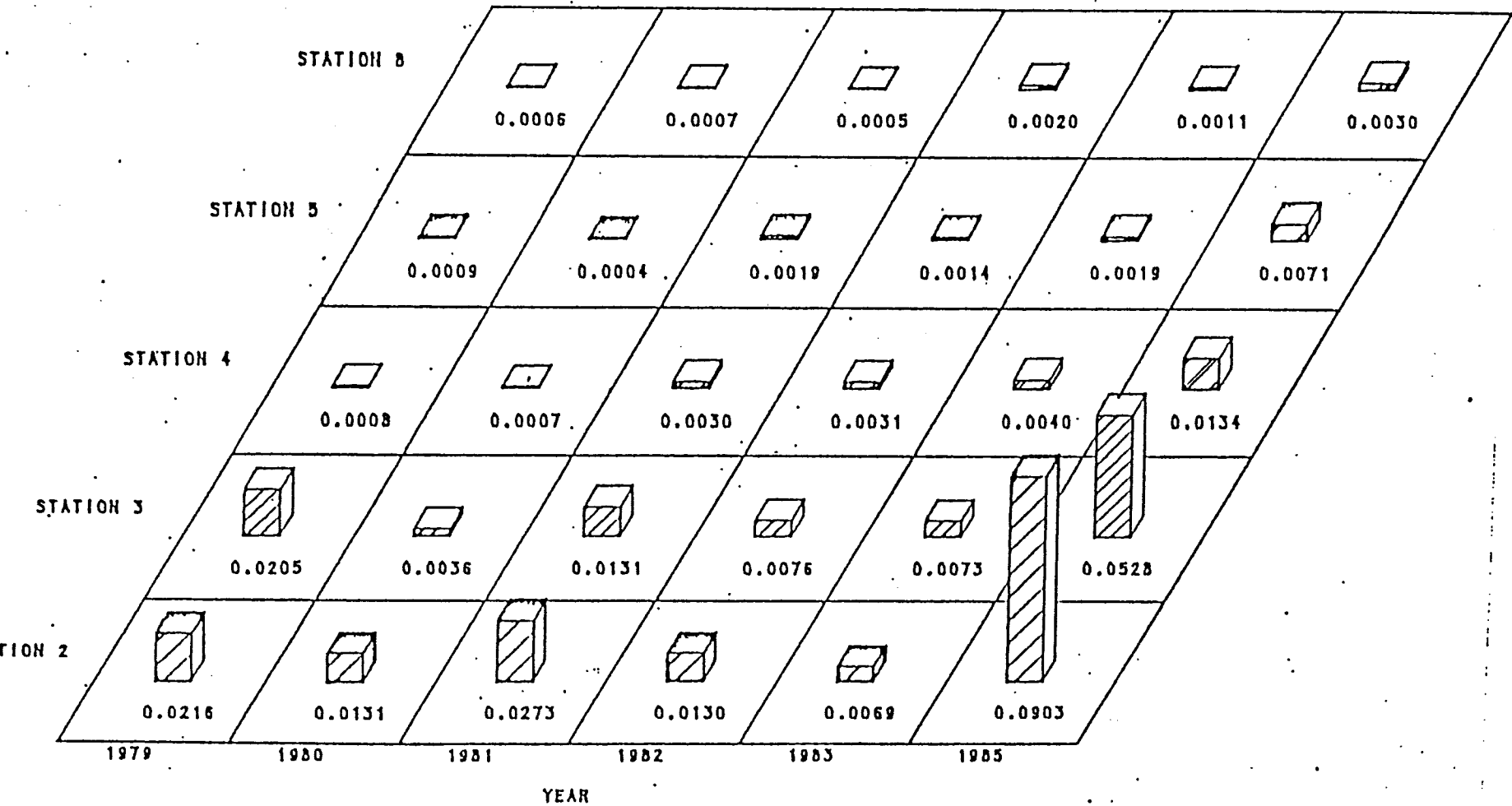
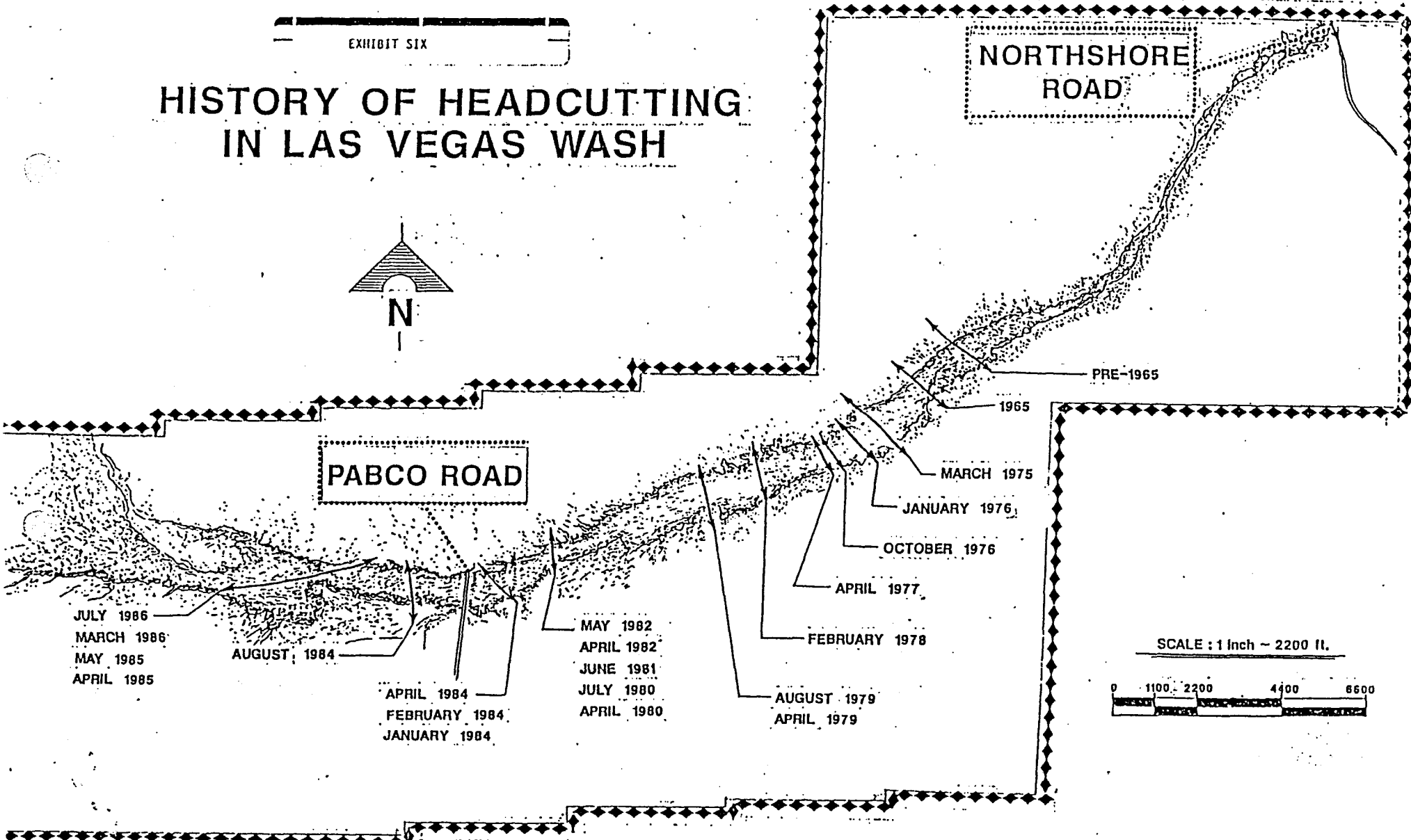

EXHIBIT FIVE

EXHIBIT SIX

HISTORY OF HEADCUTTING IN LAS VEGAS WASH



NORTHSHORE
ROAD

PABCO ROAD

PRE-1965

1965

MARCH 1975

JANUARY 1976

OCTOBER 1976

APRIL 1977

FEBRUARY 1978

AUGUST 1979

APRIL 1979

MAY 1982

APRIL 1982

JUNE 1981

JULY 1980

APRIL 1980

APRIL 1984

FEBRUARY 1984

JANUARY 1984

AUGUST 1984

JULY 1986

MARCH 1986

MAY 1985

APRIL 1985

SCALE : 1 inch ~ 2200 ft.

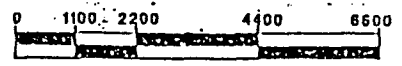

BIASES IN THE AMMONIA DATA
AND IN THE PROPOSED AMMONIA TMDL

October 1986

Introduction

At the ammonia workshop in Carson City on 11 September 1986, DEP asserted that Station 2 in inner Las Vegas Bay is subject to chronically toxic concentrations of un-ionized ammonia. This conclusion was not derived from studies of fish or aquatic life: In response to questions, representatives of DEP, the Nevada Department of Wildlife, and the University of Nevada admitted that there is no evidence whatsoever of any harm or of any toxic effect -- acute or chronic -- to any of the fauna or flora in the bay. Instead, DEP's conclusion is based only on its calculations of un-ionized ammonia. Un-ionized ammonia is calculated from measurements of total ammonia (un-ionized ammonia plus ionized ammonia), temperature, and pH.

As a result of its conclusion about chronic toxicity, DEP is proposing a water-quality standard for un-ionized ammonia. The standard is phrased in terms of a 30-day-average concentration; both DEP and EPA have asserted that a 30-day average is appropriate for assessing chronic toxicity. DEP also used 30-day averages to prepare the proposed TMDL for ammonia.

Consequently, the 30-day-average concentration of un-ionized ammonia at Station 2 is fundamental both to DEP's rationale for proposing a water-quality standards and to DEP's preparation of the ammonia TMDL. If DEP's

calculations of un-ionized ammonia are invalid, then its rationale for water-quality standards and its ammonia TMDL are invalid too.

Conclusions

There is a severe bias in the data used to calculate concentrations of un-ionized ammonia. The bias results from a failure to account for daily variations in un-ionized ammonia. Owing to natural variations, concentrations of un-ionized at Station 2 are much higher during the afternoon than they are before dawn.

The University of Nevada, Las Vegas (UNLV) generally samples near mid-day, when concentrations of un-ionized ammonia are near their daily maximum. UNLV never samples during nighttime hours, when concentrations of un-ionized ammonia are much lower. Consequently, UNLV data are biased high.

DEP's calculations of un-ionized ammonia are all derived from UNLV data, and consequently are all biased by UNLV's sampling schedule. DEP's calculated concentration of un-ionized ammonia for any day is much higher than the true average concentration for that day, and DEP's calculated monthly averages are much higher than the true monthly averages.

It is impossible to say exactly how much DEP's calculated numbers exceed the true values. However, the few available data show that DEP calculations are wrong by a factor of several hundred percent.

There are two important consequences of this bias. First, DEP's rationale for proposing a water-quality standard is no longer valid. DEP cannot say that the fish at Station 2 have been subjected to chronically toxic concentrations of un-ionized ammonia, because DEP cannot know the true concentrations at Station 2. Only one thing is certain: The true average concentrations of un-ionized ammonia were much lower than DEP asserted.

Second, because the TMDL for ammonia is derived from these biased data, it too is biased. Even if the TMDL method used by DEP were otherwise perfect, the bias would make the proposed TMDL illegitimately low by a factor of several hundred percent. No fair and accurate TMDL can be established from data having a systematic bias on the order of several hundred percent.

Origin Of The Bias

For obvious reasons, the water temperature at Station 2 tends to be higher in the afternoon than at night. The pH also tends to be higher in the afternoon, owing to the sun's effect on algal photosynthesis. DEP is well aware of the effect of photosynthesis on pH, and devoted a section to the subject in the letter dated 8 September 1986. As temperature and pH increase, the nontoxic form of ammonia (ionized ammonia) is converted into the toxic form (un-ionized ammonia); when temperature and pH decrease, the toxic form is converted back into the nontoxic form.

Consequently, one would expect to find more un-ionized ammonia at Station 2 during midafternoon than late at night.

UNLV has never measured pH, temperature, or ammonia at Station 2 between 7:00 p.m. and 7:00 a.m., according to UNLV's computerized data files. Most of UNLV's data at Station 2 have been taken during normal working hours, and it would not be unfair to say that most of the data are taken around the middle of the day. In a letter dated 29 September 1986, the City of Las Vegas pointed out that when UNLV has taken more than one set of temperature and pH readings a day at Station 2, there was a whole of a difference between early morning and mid-afternoon readings. Dr. Larry Paulson, head of UNLV's program, informed Las Vegas that during 1986 he frequently took morning and afternoon measurements of pH and temperature at Station 2, but Las Vegas has such data only for 5 and 12 June 1986, transmitted under cover letter from DEP dated 5 August 1986. A search of UNLV's computerized data files uncovered only one more date showing more than one set of pH and temperature readings at Station 2.

Magnitude Of The Bias

Table 1 summarizes the diurnal differences in percent un-ionized ammonia for the three sampling dates. Table 2 is the complete list of temperature and pH readings for the three dates.

TABLE 1

Date (y/m/d)	Time	Median Percent Un-Ionized Ammonia (0 - 3 m)	Difference Factor (Percent)
79/09/05	10:00	12.4	167
	15:15	20.7	
86/06/05	09:15	5.8	533
	15:30	31.1	
86/06/12	07:55	6.1	488
	15:45	29.4	

TABLE 2

Date (y/m/d)	Time	Depth (m)	pH	Temperature (°C)	Un-Ionized Ammonia (Percent)
79/09/05	10:00	0	8.40	25.0	12.5
		1	8.40	25.0	12.5
		2	8.40	24.8	12.3
		3	8.40	24.8	12.3
	15:15	0	8.58	27.3	20.25
		1	8.62	26.8	21.2
		2	8.63	26.6	21.4
		3	8.56	26.3	18.45
86/06/05	09:15	0	7.90	27.9	5.24
		1	7.99	28.0	6.42
		2	7.99	28.0	6.42
		3	7.83	27.9	4.24
	15:30	0	8.70	28.0	26.0
		1	8.82	28.0	31.7
		2	8.81	27.9	31.05
		3	8.81	28.0	31.2
86/06/12	07:55	0	7.39	26.6	4.71
		1	8.28	26.8	10.32
		2	8.12	26.3	7.59
		3	7.86	26.1	4.26
	15:45	0	8.92	29.2	38.8
		1	8.77	28.8	30.4
		2	8.75	28.1	28.45
		3	8.67	27.8	24.5

Source: UNLV Monitoring Data. Percent un-ionized ammonia from RV Thurston et al. (August 1979), Aqueous Ammonia Equilibrium Tabulation of Percent Un-Ionized Ammonia, Montana State University, Fisheries Bioassay Lab, Bozeman, MT.

Note: None of these data are in STORET

Effect Of The Bias On DEP's Conclusions About Chronic Toxicity

Table 3 illustrates the effect of the bias on concentrations of un-ionized ammonia by comparing morning and afternoon concentrations. Because UNLV did not measure ammonia in the mornings, the table depends on the untested assumption that there was no difference in total ammonia between morning and afternoon.

TABLE 3

<u>Date</u> (y/m/d)	<u>Time</u>	<u>Total</u> <u>Ammonia*</u>	<u>Percent</u> <u>Un-ionized**</u>	<u>Un-ionized</u> <u>Ammonia***</u>
86/06/05	09:15		5.8	29 ug/l
	15:30	500 ug/l	31.1	156 ug/l
86/06/12	07:55		6.1	72 ug/l
	15:45	1185 ug/l	29.4	348 ug/l

* From UNLV (reported as nitrogen)

** Median percent un-ionized ammonia (from Table 1)

*** Assuming no diurnal variation in total ammonia (reported as nitrogen)

Table 3 shows that the afternoon concentrations of un-ionized ammonia at Station 2 during June 1986 were hundreds of micrograms per liter, but the morning concentrations were only tens of micrograms per liter. Moreover, there is reason to believe that the concentrations were even lower before dawn. Until there is a thorough study of diurnal pH, temperature, and ammonia fluctuations in Las Vegas Bay, no one can determine the 30-day-average concentration of un-ionized ammonia at Station 2.

At the ammonia workshop on 11 September, there was some discussion about whether existing concentrations of ammonia might be harmful to fish. During that meeting, DEP reported that concentrations of un-ionized ammonia at Station 2 exceeded 400 ug/l during 1985. Some participants speculated that extended exposure to concentrations of this magnitude might result in chronic toxicity. In a letter dated 8 September 1986, DEP wrote that "We suspect that we have had sub-lethal damage to the Inner Bay fishery and food chain based on literature values of chronic ammonia toxicity."

It is now apparent that average concentrations of un-ionized ammonia at Station 2 did not exceed 400 ug/l in 1985; they must have been substantially less. Because of the bias, there is no credible evidence that the true average monthly concentrations of un-ionized ammonia exceeded literature values for chronic toxicity in 1985. DEP's conclusion about chronic toxicity in Las Vegas Bay -- and any other conclusions that depended on DEP's reported concentrations of un-ionized ammonia -- must now be re-examined. Conclusions drawn from mistaken assumptions are necessarily invalid.

Because DEP has no unbiased data, it has no credible evidence of a chronic-toxicity problem and no justification for proposing a water-quality standard for ammonia.

Effect Of The Bias On The Proposed TMDL

DEP's proposed TMDL for ammonia is derived from monthly averages of the "un-ionized fraction" (un-ionized ammonia divided by total ammonia), which in turn are calculated from the mid-day pH and temperature data. Because these pH and temperature data are biased, the monthly average un-ionized fractions are biased. When these biased monthly averages are used into the calculations, the resulting TMDL is too low by a factor of several hundred percent.

Conceptual Flaws In UNLV's Monitoring Program

The systematic bias in the data on un-ionized ammonia is a direct consequence of conceptual flaws in UNLV's monitoring program. In its letter of 8 September, DEP devoted a section to pH and algal productivity, showing that DEP is well aware of the effect of photosynthesis on pH. Dr. Paulson, a limnologist, must also know about diurnal pH variations in productive waters. The complete absence of nighttime pH and temperature readings is consequently very difficult to explain. Since both DEP and UNLV know why past monitoring programs have produced biased data, they should take immediate action to correct this conceptual flaw. DEP will never be able to calculate the true 30-day-average concentrations of un-ionized ammonia without measurements taken free of bias at all hours of day and night.

The Robust Fishery

Perhaps one reason for the apparently robust condition of the fishery in the inner bay -- a fishery that the Nevada Department of Wildlife characterizes as the best in Lake Mead -- is this: The fish have never been exposed to 30-day average concentrations of un-ionized ammonia remotely approaching chronically toxic levels (whatever those levels may be). This fish remain in the water 24 hours a day; they are not in the water only at mid-day hours. Even if all the fish remained at Station 2 all the time (which is improbable and has never been established), it is certain that their 30-day average exposure cannot be fairly estimated from the heavily biased data now on record.

Appendix D

Application of Dilution-Ratio Analysis to Assertions Made by the
Nevada Division of Environmental Protection

September 1986

Background

At the Water Quality Standards Workshop on 24 April 1986, DEP asserted that the plume is leakier now than it was in the past. The "plume" refers to the density current formed as the outflow of Las Vegas Wash moves through Las Vegas Bay, and "leakage" refers to substances that make their way from the plume to the surface waters. DEP also claimed that the increased leakage, in combination with increased loadings owing to the erosion of wetlands in the wash, threatens water quality in Las Vegas Bay. Concern about leakage from the plume appears to have motivated DEP to choose the dilution-ratio formula for calculating TMDLs.

During 1986, DEP has made the following four assertions about its methods for calculating TMDLs:

(1) The dilution ratio is a logical way of assessing leakage from the plume. In writing to Mr. Randall Walker on 8 September 1986, DEP asserted that "the dilution ratio is an uncomplicated and logical way to relate Wash to Bay nutrient concentrations, given the current state of the art of modeling plunging flows." This assertion was also made to Dr. Douglas Selby and Mr. Donald L. "Pat" Shalmy in letters dated 15 August and 8 September 1986.

(2) The dilution-ratio formula used in the TMDLs takes into account hydrologic, chemical, and biological processes. In its letters to Messrs. Walker and Shalmy and Dr. Selby, DEP asserted the following:

Because the ratio incorporates actual measured nutrient values, it takes into account the hydrologic, chemical, and biological processes in the water which are automatically encompassed during any sampling. Therefore, the value of the dilution ratio will be different for different substances and it implicitly takes into account chemical transformations by variation in its value. It is for this reason we have no reservations in predicting a non-conservative substance such as ammonia with the formula.

(3) The dilution-ratio formula is based on relatively constant plume dynamics. In the same letters, DEP asserted that the ratio represents "equilibrium conditions (1981-1985)" and is based on "relatively constant annual flow rate, nutrient input concentrations, plume dynamics, and lake level."

(4) There was a major change in plume dynamics in 1981. Although phosphorus loads fell precipitously in 1981 when the City of Las Vegas and Clark County began chemically removing phosphorus, there was no corresponding change in phosphorus concentrations or chlorophyll in the lake. During informal discussions and during the Water Quality Standards Workshop on 24 April 1986, DEP asserted that this lack of change in lake concentrations could be explained by a change in the plume dynamics.

DEP has relied on these four assertions to explain the failure of chemical phosphorus removal in lowering phosphorus and chlorophyll concentrations in the bay. DEP is now relying again on these assertions in prescribing suggested TMDLs for phosphorus and ammonia. These assertions are essential to DEP's rationale.

We tested these assertions in a traditional manner by assuming the first assertion to be true; we then examined the facts and the essentials of the argument to assess whether the remaining three assertions were consistent

with the first. This test may be called the logical-consistency test. This paper is not an endorsement of the first assertion; the first assertion is assumed to be true merely for the purposes of this logical test.

Conclusions

DEP's four assertions fail the logical-consistency test. The application of dilution-ratio analysis to DEP's calculations shows that leakage from the plume is a relatively unimportant determinant of water quality in Lake Mead. The major determinants are what may be called nondilutional processes. Although one can speculate about what these processes might be, no one has attempted to identify or quantify them anywhere in Lake Mead. In short, neither DEP nor anyone else knows anything about the major determinants of water quality in the lake.

Moreover, these unknown nondilutional processes are extremely unstable from year to year -- more unstable than the dilution ratio itself. One of the essential assumptions of DEP's proposed TMDLs -- that conditions were stable during 1981-1985 -- is plainly false. DEP has assumed that the dilution ratios calculated for 1981-1985 conditions will be duplicated in the future. Although this assumption is not demonstrably false, it is exceedingly improbable. Because no one has identified or quantified the nondilutional processes, no one can explain why they have been so variable since 1979 and no one can confidently predict that the nondilutional processes in future years will be consistent with those calculated for 1981-1985.

Lastly, there is no evidence of a major change in plume dynamics in 1981. Rather, the failure of chemical phosphorus removal to affect water quality in the lake must be attributed to nondilutional processes. By attempting once again to regulate water quality without understanding its

principal determinants, DEP is inviting failure again. DEP risks failure this time because the proposed TMDLs and the effluent limits derived from them will be ineffective, unnecessary, or both.

Importance of Differential Behavior of Dilution Ratios

In his letter of 9 May 1986 to Mike Reed, Jerome Horowitz pointed out that the calculated dilution ratios for conductance differed greatly from those for ammonia, phosphorus, and nitrogen. Here are the July-September averages of DEP's calculated dilution ratios for Station 2:

TABLE 1

<u>Year</u>	<u>Cond</u>	<u>TAN*</u>	<u>TP</u>	<u>TN</u>
1979	22.9	77.7	51.2	40.5
1980	17.5	190.1	39.4	20.9
1981	15.0	145.4	5.5	8.8
1982	12.9	69.5	12.3	15.3
1983	7.6	151.5	22.3	35.3
1985	10.1	25.0	15.7	9.7

*Total Ammoniacal Nitrogen

Horowitz concluded that "dilution ratio" must be a misnomer:

No doubt dilution is one component of this "dilution ratio", but it is confabulated with other things and processes. If dilution alone were represented in these ratios, the ratios for TP, TN, Conductivity, and Ammoniacal Nitrogen should be identical. Of course, they are nothing of the kind

DEP has accepted this conclusion. In its letters to Messrs. Walker and Shalmy and to Dr. Selby, DEP has conceded that the ratio "takes into account the hydrologic, chemical, and biological processes in the water". Chemical and biological processes are not dilutional processes.

The differential behavior of the four dilution ratios is proof positive that "dilution" is a deceptive and misleading label. If dilution explained everything, the four dilution ratios would be identical.

Differences between the ratios for conductance and ammonia are especially noteworthy because both conductance and ammonia are soluble constituents of the plume. Differences between the conductance ratio and the other ratios can be used to assess the magnitude and significance of nondilutional processes operating on the plume as it moves into and through Las Vegas Bay.

Why are Dilution Ratios for Ammonia So Much Higher Than Those for Conductance?

Of the dilution ratios DEP calculated, the ratio for conductance is the least likely to be confabulated with nondilutional processes because conductance is not substantially affected by sedimentational, biological, and other nondilutional processes likely in Lake Mead. Consequently, an estimate of the nondilutional processes affecting ammonia can be obtained by comparing the dilution ratio for conductance with the dilution ratio for ammonia.

The first three columns in Table 2 (below) show the results of this comparison; these columns were taken from Table 1. The fourth column, which provides a "dilution ratio" for the nondilutional processes affecting ammonia, was derived by subtracting the dilution ratio for conductance from the dilution ratio for ammonia (i.e. the number in the third column was subtracted from the corresponding number in the second column). The fifth and sixth columns, which provide a measure of the relative importance of dilutional and nondilutional processes, were derived by dividing the numbers in the third and fourth columns by the corresponding number in the second column. In interpreting the dilution ratios, it is important to bear in mind that a high value purports to mean that a great deal of ammonia disappeared between Northshore Road and Station 2; a low value purports to mean that little ammonia disappeared.

TABLE 2

1 Year	2 TAN*	3 Cond (DP)**	4 TAN - Cond (NDP)***	5 Cond/TAN	6 NDP/TAN
1979	77.7	22.9	54.8	29%	71%
1980	190.1	17.5	172.6	9%	91%
1981	145.4	15.0	130.4	10%	90%
1982	69.5	12.9	56.6	19%	81%
1983	151.5	7.6	143.9	5%	95%
1985	25.0	10.1	14.9	40%	60%

* Total Ammoniacal Nitrogen
 ** Estimate of dilutional processes
 *** Estimate of nondilutional processes

Table 2 shows that nondilutional processes account for most of the ammonia disappearance between Northshore Road and Station 2. Leakage from the plume never accounted for more than forty percent of the disappearance; in three of the six years it accounted for ten percent or less of the disappearance. Clearly, nondilutional processes overwhelmed dilutional processes.

Most of the Changes in the Ammonia Ratio Are Attributable to Nondilutional Processes

The concentration of ammonia in surface waters at Station 2 is always much lower than ammonia concentrations at Northshore Road, but in 1985 Station 2 ammonia concentrations were much higher than usual. Exhibit 1, prepared by DEP, shows that average summertime ammonia concentrations at Station 2 increased by a factor of ten -- a 1,000% increase -- between 1983 and 1985. This enormous change cannot be explained by increased leakage from the plume. According to DEP calculations summarized in Table 2, the plume leaked less in 1985 than in 1983. But nondilutional processes can explain the change: As Table 2 shows, nondilutional processes plummeted by roughly a factor of ten between 1983 and 1985 (see column 4).

Nondilutional Processes Affecting Ammonia Are Unstable

To avoid confusion, we will call the dilution ratio for nondilutional processes the "nondilution ratio".

Table 2 shows that leakage from the plume, as measured by the dilution ratio for conductance, was relatively stable during 1981-1985, the interval DEP calls "equilibrium conditions". The nondilution ratio, however, was extremely unstable. From year to year it typically rose or fell by a factor of two or three, although in 1985 it fell by a factor of ten. To put these variations into perspective, imagine three years when the average summertime temperature rose from 70°F to 210°F and then fell to 21°F. Whatever else they may be, these are not equilibrium conditions.

Because the nondilution ratio is so inconsistent from year to year, neither DEP nor anyone else can reliably predict future ammonia concentrations in Lake Mead. The data available in 1983, which showed that nondilution ratios were always in the range of 54.8 to 172.6, gave no hint that the ratio would be 14.9 in 1985. No one could have predicted the 1985 nondilution ratio with any confidence, and there is every reason to doubt that anyone can confidently predict future nondilution ratios now.

No One Has Investigated Nondilutional Processes Affecting Ammonia in Lake Mead

If the plume was not leaking more in 1985 than in 1983 (see Table 2, column 3), what caused the drastic increase in ammonia concentrations that year? No one knows.

Anyone might hazard a guess about the nature of the nondilutional processes affecting ammonia. Between Northshore Road and Station 2, ammonia may be nitrified, consumed by algae, or adsorbed onto particulates (both organic and inorganic) and sedimented. However, no one has investigated

which, if any, of these processes actually affect the concentrations of ammonia in Las Vegas Bay and Lake Mead. No one has investigated their relative magnitudes or tried to identify the causes of their variability.

Virtually nothing is known about the processes controlling ammonia concentrations at Station 2. No one can do more than speculate about the nature of the nondilutional processes, why they have varied so much in the past, and how they will act in the future.

Comparison of Dilution Ratios for Phosphorus and Conductance

Table 3 (below) shows dilution ratios for phosphorus and conductance at Station 2; it is organized in the same manner as Table 2. Once again the first three columns were taken from Table 1. The fourth column (the nondilution ratio for phosphorus) was derived by subtracting the dilution ratio for conductance (column 3) from the corresponding dilution ratio for phosphorus (column 2). The fifth and sixth columns were calculated by dividing the numbers in the third and fourth columns by the corresponding numbers in the second column.

TABLE 3

1 Year	2 TP*	3 Cond (DP)**	4 TP - Cond (NDP)***	5 NDP/TP	6 Cond/TP
1979	51.2	22.9	28.3	55%	45%
1980	39.4	17.5	21.9	56%	44%
1981	5.5	15.0	-9.5	-173%	273%
1982	12.3	12.9	-0.6	-5%	105%
1983	22.3	7.6	14.7	66%	34%
1985	15.7	10.1	5.6	36%	64%

* Total phosphorus
 ** Estimate of dilutional processes
 *** Estimate of nondilutional processes

Two of these results -- the negative nondilution ratios in 1981 and 1982 -- are startling. A negative nondilution ratio implies that there

are processes concentrating phosphorus in the surface waters of Station 2. These concentration processes apparently predominated over all other dilutional and nondilutional effects in 1981. Although pollution-control agencies have been studying and speculating about phosphorus and water quality in Lake Mead for nearly two decades, no one has ever suggested that concentration processes might affect phosphorus concentrations in Las Vegas Bay.

Before accepting these startling conclusions about concentration processes, it would be wise to check the calculations of dilution ratios and the data from which they are calculated. It would also be prudent to bear in mind the algebraic effects mentioned in Jerome Horowitz' letter to Mike Reed on 9 May 1986. This paper relies on DEP's calculations of monthly average dilution ratios, as reported in the printout dated 15:20 Wednesday, March 19, 1986. There is another possible explanation for the negative dilution ratios and for other apparent effects noted in this paper: DEP's data, calculations, or both are wrong.

The Nondilution Ratio for Phosphorus Is Not Stable

Table 3 shows that there are at least two kinds of nondilutional processes affecting the phosphorus concentration at Station 2. One process usually increases the phosphorus concentration; the other process usually decreases it. These two antagonistic processes are not in balance. In four of the six years on record, the net result of these two opposing forces was a positive nondilution ratio; in two years, however, it was a negative nondilution ratio.

This instability prevents reliable predictions of future nondilution ratios. If there were a simple repetitive pattern to the nondilution

ratios, prediction would be easy. But there is no obvious pattern -- there is not even a tentative hypothesis to explain the flip-flopping between positive and negative. Until something is known about the causes of the negative nondilution ratios, and about whether they are recurrent or aberrant, reliable predictions of future nondilution ratios are impossible.

The Failure of Chemical Phosphorus Removal Cannot Be Attributed to Increased Leakage from the Plume

From the 1960's onward, DEP and others predicted that phosphorus removal at the municipal sewage-treatment plants in Las Vegas Valley would substantially lower chlorophyll concentrations in Las Vegas Bay. Because of these predictions, multi-million-dollar facilities for phosphorus removal were built and in 1981 phosphorus removal began. Although the phosphorus load in Las Vegas Wash decreased by about 80-90% in 1981, there were no substantial changes in either chlorophyll or phosphorus concentrations in inner Las Vegas Bay. DEP has shown slides and distributed figures showing that phosphorus concentrations were higher in 1981 and 1982 than they were in 1980:

TABLE 4

<u>Station</u>	<u>Total Phosphorus (ug/L)</u>		
	<u>1980</u>	<u>Year</u> <u>1981</u>	<u>1982</u>
2	77	92	85
3	54	63	65
4	21	25	35

Source: DEP materials shown at the Water Quality Standards Workshop on 24 April 1986 and transmitted by James J. Cooper (DEP) to Jerome Horowitz (CLV) on 30 April 1986

DEP has repeatedly asserted that the plume became much leakier in 1981, thereby offsetting the improvements from phosphorus removal. Table 3,

however, shows that the plume did not become dramatically leakier in 1981. Rather, the failure of chemical phosphorus removal must be attributed to the apparent concentration processes that dominated in 1981.

No One Has Investigated Nondilutional Processes Affecting Phosphorus in Lake Mead

Hungry fish are undoubtedly one of the nondilutional processes affecting the phosphorus concentration at Station 2. Because the sampling equipment used in UNLV's nutrient-monitoring program does not catch fish, the chemical analyses for nutrients performed in UNLV's laboratory cannot account for the phosphorus in the fish. But fish lower the measured concentrations of phosphorus in the bay by eating algae and zooplankton, which contain phosphorus and which are included in UNLV's phosphorus analyses. Since the Lake Mead fishery is of great importance to southern Nevada and to DEP, one might think that there had been a great deal of study on the transformation of sewage phosphorus into fish flesh. Sadly, there has been none.

Other nondilutional processes might include sedimentation of either organic or inorganic phosphorus. However, no one has identified which of these processes actually affect phosphorus in Las Vegas Bay and Lake Mead, no one has quantified their effects, and no one has tried to explain their variability. In short, virtually nothing is known about the nondilutional processes affecting phosphorus.

Fundamental Weaknesses of the TMDLs

The "dilution ratio" misnomer hides fundamental weaknesses in the theoretical foundations of the TMDLs. The dilution ratio cannot explain

why nondilutional effects overwhelm dilutional ones. It cannot explain why nondilutional effects are so unstable. It cannot predict what future dilution ratios will be. It contradicts DEP's assertion that equilibrium conditions existed during 1981-1985. It contradicts DEP's assertions that the failure of chemical phosphorus removal since 1981 can be blamed on increased leakage from the plume. For all these reasons, the dilution ratio formula cannot be legitimately used in the proposed TMDLs.

TOTAL AMMONIA - MG/L

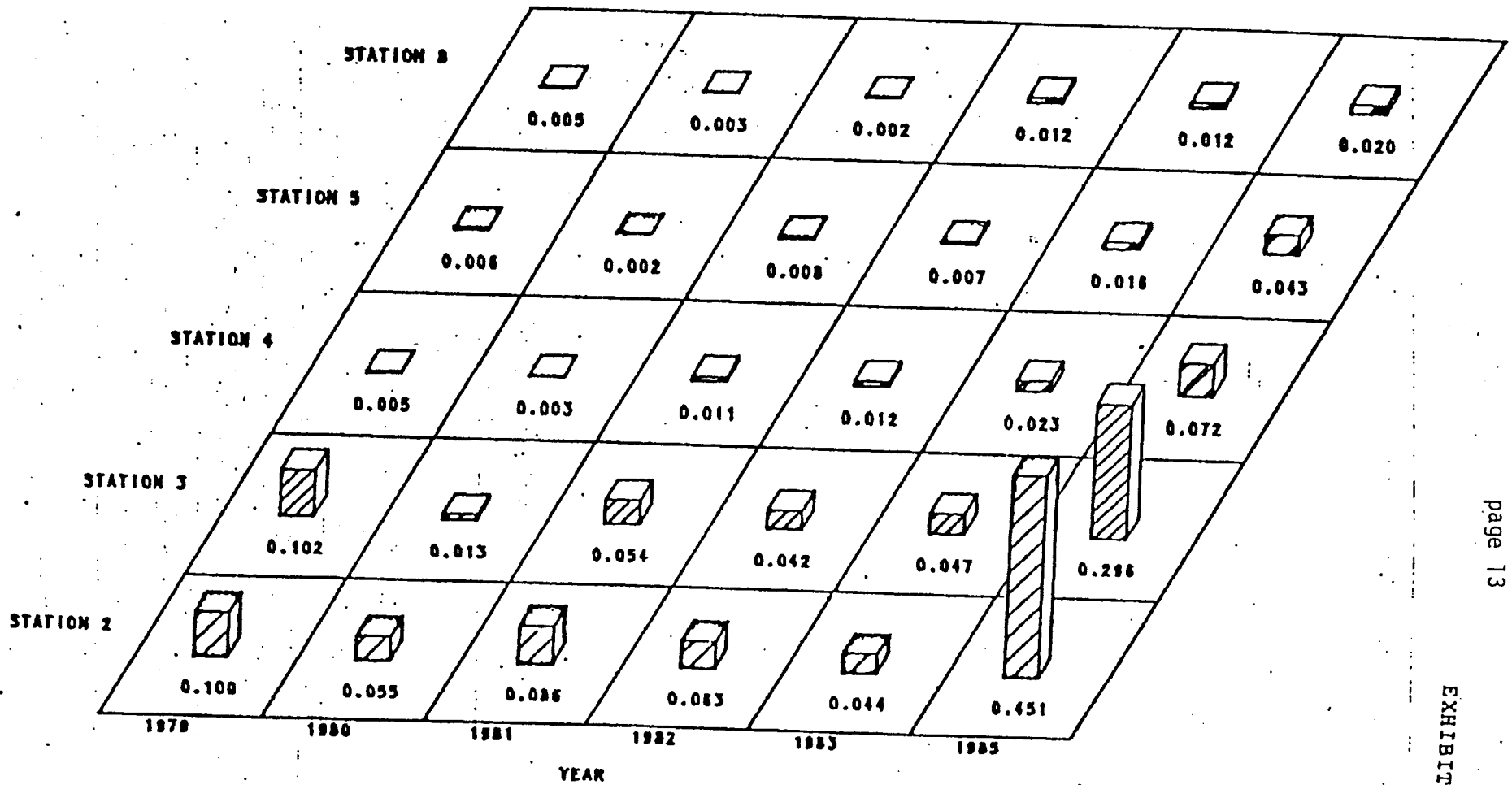

Appendix E

Enclosure (1): Analysis of the Dilution Ratio Formula Used by the Nevada Division of Environmental Protection in Its TMDL Calculations For Phosphorus and Ammonia In Las Vegas Bay, Lake Mead

August 1986

Background

DEP proposed TMDLs for ammoniacal nitrogen and total phosphorus on 24 April 1986 and revised both on 25 June 1986. All four TMDLs make use of a simplified dilution calculation developed by Brown and Caldwell (BC), Draft Water Quality Standards Study, March 1982, pp. 8-103 & 8-104. This simplified dilution calculation has no relation to the hydraulic model of the plume developed elsewhere in that report (see especially Appendix F, separately bound).

Summary of the Four Fundamental Failings of BC's Dilution Ratio

BC's formula (Equation 6 on p. 8-104) suffers from four fundamental flaws:

- (1) The formula depends on invalid assumptions about Las Vegas Bay. BC assumed that there are two distinct volumes of water in Las Vegas Bay, each homogeneous, one overlying the other, and clearly divided by the plume interface. It also assumed that the discharge from Las Vegas Wash moves through the bay as a distinct plume that does not entrain any lake water. Lake data prove beyond any doubt that these assumptions are wrong and that the formula does not represent reality.
- (2) What BC calls $c(w)$ is not the Northshore Road concentration at all; it is instead one of the several hypolimnetic concentrations

at Station "s", and we may label it $c(sh)$. Without a value for $c(w)$, it is impossible to calculate a TMDL at Northshore Road using this formula.

- (3) BC claimed that "the validity of equation (6) for describing dilutions actually occurring in the bay was tested by regression analysis of wash and surface concentrations" (p. 8-104). These regressions, however, misrepresent the real relationships between wash and bay concentrations because they include falsely plotted points. Once these points are removed, or correctly plotted, the regressions BC reported vanish, and the data are seen to be hopelessly scattered, with no consistent relationship among the variables.
- (4) BC's formula is deterministic: It assumes that the relations among $c(w)$, $c(s)$, and $c(b)$ conform perfectly with equation (6) on BC page 8-104. The true relations among these three concentrations can be estimated from scatterplots of Northshore Road concentrations versus concentrations in the bay and lake. Because these scatterplots show no stable, consistent, predictable relations among these variables, a deterministic model is out of the question.

Fundamental Assumptions Are Wrong

BC's dilution-ratio formula was an attempt at a simplified model sufficiently accurate to produce reliable descriptions and predictions of the wash plume and Las Vegas Bay. The model is diagrammed in BC Figure 8-53

(see Attachment 1). BC explicitly asserts that the model describes the basic features of the system, and implicitly claims that, despite the simplifications, it substantially approximates the reality of Las Vegas Bay. In fact, the model is so far removed from reality that the two bear almost no resemblance.

There Is No Stable, Predictable Plume Interface

The dilution-ratio formula depends on the underlying assumptions that there are two distinct volumes of water in Las Vegas Bay, that each is homogeneous, and that they are divided by a well-defined boundary, the plume interface. The truth, however, is that there is no clear distinction between the plume and the waters overlying it. Some examples of actual conditions in Las Vegas Bay are shown below. These examples are from late July, when the lake is warmest, stratification is generally strongest, and when one might expect to find a clear interface between the plume and the overlying water. These data represent the condition DEP used for its TMDL calculations, July-September.

At Station 2, UNLV takes nutrient samples in only two ways: (1) a 2.5 meter depth-integrated sample, and (2) a grab sample at the depth where conductance is highest (the so-called "plume sample"). Neither sample is reliably taken below the thermocline shown on fig. 8-53 because the lake is often not strongly stratified at Station 2. There is no clear plume interface at Station 2 either, as the vertical conductance profiles show. Instead, there is an area of great instability, as might be expected in a lacustrine estuary where the tributary water mixes erratically and incompletely into the receiving lake water. The absence of a clear interface is demonstrated by the following examples:

Conductance at Station 2, micromhos/cm

<u>Depth (m)</u>	<u>07/21/81</u>	<u>07/29/82</u>	<u>07/18/85</u>	<u>07/21/85</u>
0.0	1280	1230	1080	1040
1.0	1320	1260	1070	1040
2.0	1320	1220	1070	1020
3.0	1340	1220	1070	1020
4.0	1390	1350	1080	1030
5.0	1470	1440	1090	1040
6.0	1540	1490	1090	1110
7.0	1530	1550	1090	1470
8.0	1680	1670	1100	1620
9.0		1720	1180	
10.0			1250	
11.0			1290	
11.5			1300	

Source: UNLV Monitoring Data

These data for Station 2 do not show a regular, clear interface between the plume from the wash and the receiving lake water; the nearest approximation is the data set for 07-21-85. Nor do these data show that the plume was leakier in 1985 than in 1981 or 1982: Indeed, surface conductances were much higher in 1981 and 1982 than in 1985, and peak conductances were lower in 1985 than in the earlier years.

At Stations 3-5 and Station 8 the lake is commonly stratified in the summer. UNLV takes two kinds of samples at these stations: (1) a 5-meter depth-integrated sample, and (2) a grab sample at the depth where conductance peaks. UNLV's vertical conductance profiles at these stations do not show a reliable, clearly defined plume interface, not even in late July when stratification is commonly strongest and surface temperatures are highest. Here are examples from Station 4 in late July:

Depth (m)	Conductance (micromhos/cm)		
	07/21/81	07/29/82	07/25/85
0.0	1200	1100	980
1.0	1240	1100	980
2.0	1230	1100	980
3.0	1230	1110	970
4.0	1220	1100	970
5.0	1220	1100	970
6.0	1220	1150	960
7.0	1200	1150	980
8.0	1180	1080	1000
9.0	1200	1130	1110
10.0	1210	1120	1240
11.0	1180	1110	1480
12.0	1180	1150	1460
13.0	1190	1210	1300
14.0	1200	1170	1130
15.0	1190	1150	1030
16.0	1180	1130	1020
17.0	1190	1110	990
18.0	1190	1110	980
19.0	1200	1120	940
20.0	1190	1110	940
21.0	1200	1090	ND
22.0	1200	1090	ND
22.5	ND	ND	930
23.0	1190	1090	ND
24.0	1180	1090	ND
25.0	1180	1090	930
26.0	1170	1080	ND
27.0	1170	1070	ND
27.5	ND	ND	920
29.0	ND	ND	ND
30.0	ND	ND	920
32.5	ND	ND	920

In 1981, there were local maxima at 1, 10, 14, 19, and 21 m, and the peak conductance was at 1 m. In 1982 there were local maxima at 6, 9, 13, and 19 m, and the peak conductance was at 13 m. In 1985 the local maxima were at surface and 11 m, and the peak conductance was at 11 m. These data suggest that the plume was far less leaky in 1985 than in either 1981 or 1982, and that even in 1985 the plume had a rather hazy "interface" extending between 9 and 15 m.

These data do not suggest that the plume can be reliably predicted with respect to depth, vertical extent, or absolute concentration from year to year, not even in late July when the lake is most strongly stratified. The behavior of the plume seems to be inconsistent and unpredictable, but the dilution ratio formula DEP selected requires the plume to have a clearly defined interface, and preferably a stable one at that.

We have already shown that there is no stable, predictable plume interface at Station 2 using conductance as a plume marker in late July, when stratification is generally strongest in Lake Mead. BC's intensive dye survey in the spring of 1980 provides even more striking evidence. Here are data from 3 May 1980, at the end of the dye release (Day 8); dye concentrations had been running 20-30 ppb at Northshore Road for the previous 24 hours, and winds over the lake were running 2-10 miles an hour (which are not unusual measurements for Lake Mead). Dye concentrations are reported in ppb (ug/L) at BC Station 3 located near UNLV's Station 2:

Depth (m)	Time of Day				
	<u>03:36</u>	<u>08:21</u>	<u>13:17</u>	<u>16:09</u>	<u>20:22</u>
0.30	1.23	1.77	1.25	0.76	1.44
1.00	1.23	2.19	1.25	0.51	1.44
2.00	4.79	2.01	ND	0.68	1.42
3.00	3.84	1.58	3.69	ND	3.17
4.00	4.47	2.76	5.79	2.85	6.12
5.00	10.70	5.72	6.99	3.30	2.53
6.00	11.40	8.88	7.55	4.08	5.62
7.00	7.08	7.08	8.88	5.14	8.14
8.00	ND	7.03	6.25	9.01	6.31
9.00	5.20	6.20	5.47	9.91	5.42
10.00	7.20	6.97	7.90	9.78	5.44
11.00	ND	10.36	8.75	7.13	7.11
bottom	7.29	10.35	10.35	7.13	7.11

ND = Not Done

BC's dye data clearly show the instability of the plume near UNLV Station 2 in early May. Dye concentrations greater than 2 ppb were reported at every depth between one meter and the bottom; dye peaks varied from bottom to as high as 6 meters, and the depth of the peak changed every few hours. There was no clear interface at any time, and strong secondary peaks were common in each measurement set. Of course, the lake is much less strongly stratified in May than in late July, when surface temperatures are highest; however, May is one of the months included in DEP's ammonia TMDL calculations, and these calculations require that there must be a clear plume interface.

Misidentification of c(w).

BC Figure 8-53 (shown in Attachment 1) is mislabeled. What BC calls c(w), the concentration at Northshore Road, is actually one of several hypolimnetic concentrations at Station "s". It must be correctly labeled c(sh), not c(w). BC's mislabeling is a consequence of the underlying assumption that lake water is not entrained into the plume -- that is, that the plume does not become increasingly dilute as it moves through Las Vegas Bay. This assumption is false.

Here are the conductances at Northshore Road matched as closely as possible with the conductance profiles for Station 2 given above:

<u>Date</u>	<u>Northshore Road micromhos/cm</u>	<u>Max at Station 2 micromhos/cm</u>
07/21/81	2930 (UNLV)	1680
07/29/82	2580 (UNLV)	1720
07/15/85	2500 (CCSD)	
07/18/85		1300
07/21/85		1620
07/22/85	3400 (CCSD)	
07/29/85	3000 (CCSD)	

Notice that conductances at Station 2 were always much lower than conductances at Northshore Road. UNLV's measurements prove beyond any doubt that $c(\text{sh})$ is never equal to $c(\text{w})$, not even at Station 2 for conductance, which is biologically inert.

Since hypolimnetic concentrations regularly diminish as the distance increases from Northshore Road, $c(\text{w})$ becomes an increasingly inadequate overestimate of $c(\text{sh})$ as the distance increases from Northshore Road. At Station 5, $c(\text{w})$ is commonly 200 percent higher than $c(\text{sh})$:

<u>Date</u>	<u>Northshore Road micromhos/cm</u>	<u>Max at Station 2 micromhos/cm</u>	<u>Max at Station 5 micromhos/cm</u>
10/21/81	3190	1890	1210
05/12/82	3450	2150	1350 (at surface)
08/19/83	3210	1910	1840
08/15/85	3000	1420	1040

There is nothing special about these examples: More dramatic examples are easy to find. But these examples show that $c(\text{w})$ is always a gross overestimate of $c(\text{sh})$ and a highly erratic one too. For substances like total ammoniacal nitrogen, the estimate is much worse: $c(\text{w})$ commonly ran about 12 mg/L in 1985, but plume samples at Station 2 ran about 1 - 5 mg/L and at Station 5 they ran about 0.1 - 0.6 mg/L. In other words, $c(\text{w})$ was sometimes 1,000 percent higher than the plume samples at Station 2, and 10,000 percent higher than those at Station 5.

Without $c(\text{w})$, No TMDL Is Possible

BC's dilution equation attempts to relate $c(\text{w})$, $c(\text{s})$, and $c(\text{b})$. Without $c(\text{w})$, there is no way to relate concentrations in the lake with those at Northshore Road. BC's equation (6) on p. 8-104 reads:

$$D = \frac{c(\text{w}) - c(\text{s})}{c(\text{s}) - c(\text{b})}$$

In order to correspond correctly with conditions in the lake, it must be modified as follows:

$$D = \frac{c(\text{sh}_i) - c(\text{se}_j)}{c(\text{se}_j) - c(\text{b}_k)}$$

where $c(\text{sh}_i)$ is the set of hypolimnetic concentrations at Station "s"
 $c(\text{se}_j)$ is the set of epilimnetic concentrations at Station "s"
 $c(\text{b}_k)$ is the set of concentrations at Station 8

Even if usable values of the index sets (i,j,k) can be identified -- and it is by no means certain which of them should be used -- the cold fact remains that there is no value for $c(w)$ in the corrected equation. Consequently, this equation cannot be used for setting a TMDL at Northshore Road.

The Dilution-Ratio Formula Fails The Reality Test

In summary, the dilution-ratio formula fails a basic test for a model: Does it accurately simulate reality? The formula is derived from a model that plainly does not simulate Las Vegas Bay. As shown above, the differences between model and reality are not trivial; on the contrary, there is barely any similarity between them.

BC might argue that the model was never supposed to be an accurate simulation, just a useful simplification. In general, a simplified model or formula may be considered useful if it can reliably simulate some aspect of reality. The usefulness of the dilution-ratio formula, however, has not been demonstrated. BC attempted to test the formula against actual data, but plotting errors led to unjustified conclusions.

The Dilution-Ratio Formula Fails The Regression Test

BC claimed on p. 8-104 that the validity of the dilution equation "for describing dilutions actually occurring in the bay was tested by regression analysis of wash and surface concentrations". Further explanation of this procedure and of its results begins on p. 8-151:

"The simplified material balance (Figure 8-53 [Attachment 1]) and the resulting dilution equation (7 [sic: 6 is meant]), suggest that a straight line relationship exists between wash input concentration and surface concentrations at stations in the bay. The slope of the line should be $1/(D+1)$ and the intercept should be approximately $c(b)$, the background concentration. This relationship was tested by correlation of input concentrations (Wash Station 5) with bay surface concentrations at Stations 2, 3, and 4. Dilutions were computed from average monthly data for specific conductance, total phosphorus, and total nitrogen. Values of the r^2 statistic from linear regressions ranged from 0.04 [sic] to 0.65, as shown in Table 8-23 [Attachment 3]. Lower values were found at the outer stations where physical conditions contribute to greater variability. Scatter diagrams of the data, including the average background concentration, illustrate the relationships found between influent and surface concentrations (Figures 8-70 to 8-72 [Attachment 2]). Based on the correlation results, additional analysis was conducted using the simplified mass balance dilution relationship."

The principal error was the inclusion of a falsely plotted point: "the intercept should be approximately $c(b)$, the background concentration". Look carefully at Figure 8-70 on p. 8-153 (Attachment 2). Notice that $c(b)$ has a Y value of approximately 1175 micromhos/cm, but the X value associated with that Y value is zero. The conductivity at Wash Station 5 was never anything remotely approaching zero. The $c(b)$ value of 1175 is properly associated with a wash conductance of approximately 3200. When this point is correctly plotted at $Y = 1175$ and $X = 3200$, it falls smack in the middle of the highly scattered values for $c(s)$. Without the falsely plotted value of $c(b)$, there is nothing but hopeless scatter in the region

bounded by $X = 2700$ to 3900 and $Y = 1075$ to 1290 . The only linear fits to the correctly plotted data are nearly vertical and horizontal regression lines giving an r^2 of approximately zero.

We have singled out conductance for analysis because it gave the highest values of r^2 according to BC: 0.65 at Station 2 and 0.64 at Station 3. The r^2 at Station 4 fell to 0.16 not because "Lower values were found at the outer stations where physical conditions contribute to greater variability", as BC explained on p. 8-151. Figure 8-70 shows that the scatter for Station 4 points was no greater than the scatter for Station 3. The value of r^2 fell at Station 4 only because the average conductance at Station 4 was nearly equal to the average conductance at Station 8; consequently, the regression line had almost no slope. The higher values of r^2 at Stations 2 and 3 are purely an artifact arising from the difference between the average background conductance (about 1175) and the average conductance at the inner bay stations. Remove the falsely plotted point for c(b) or plot it correctly at $X = 3200$ rather than at $X = 0$ and the high values for r^2 vanish. Furthermore, the difference in slope between the regression lines for Stations 2 and 3 is exaggerated because the regression line for Station 2 has obviously been misplotted. Only the single highest value for Station 2 falls on the line; all the other points -- excepting the falsely plotted point for c(b) -- lie well below the so-called regression line in BC figure 8-70.

The falsely plotted point c(b) appears in all three of BC's scatterplots. In each case, the scatter may be seen for what it really is by correctly

plotting the value of $c(b)$. Once the data are correctly plotted, the regression lines BC shows vanish, and so do all of BC's claims for having demonstrated the validity of the simplified dilution equation by regression analysis.

A Deterministic Equation Is Entirely Inappropriate

The dilution-ratio formula is what mathematicians call deterministic. The relations among $c(w)$, $c(s)$, and $c(b)$ are assumed to be completely determined by the simplified model shown in Figure 8-53 on p. 8-103, and these relations are assumed to be precisely those given in BC's equation (6).

If it could be shown from the data that there is a tight fit of values for $c(s)$ as a function of $c(w)$, i.e. that $c(s) = f(c(w))$ with little scatter, BC's equation would be easy to defend. But nothing of the kind is true. Look, for example, at Figure 8-70 with $c(b)$ correctly plotted. There is no decent relationship between $c(w)$ and $c(2)$ or $c(3)$ or $c(4)$. The true relations among these terms cannot be specified. We can say only that the relations are erratic and unpredictable. Under these conditions, it is mathematically unacceptable to represent these relations in a deterministic equation.

Figure 8-70 is not a fair representation of the true scatter because all the points shown are claimed to be "average monthly data" (p. 8-151). The monthly averages hide all the scatter measured during the month. For example, surface conductance at Station 2 ranged from 1060 to 1250 in April 1980, from 1130 to 1370 in May 1980; in 1985 the scatter was no better: 1030 to 1250 at Station 2 in May, 1100 to 1400 in June. Bad as the scatter

is in Figure 8-70, much of the true scatter is hidden by BC's having plotted only the monthly averages rather than the actual daily readings. The instabilities shown in these scatterplots are concrete evidence that deterministic models are out of place in dealing with these data.

Material balances can be applied to each segment of the bay to develop desired wash-surface concentration relationships. The result for Segment 1-2 comparable to equation (4) is:

$$c_{m2}/Q_w = \frac{(c_w - c_{p1})}{(c_{p1} - c_1)} \left(\frac{c_1 - c_2}{c_{p2} - c_2} \right) - \left[1 + \frac{(c_w - c_{p1})}{(c_{p1} - c_1)} \left(\frac{c_{p1} - c_{p2}}{c_{p1} - c_1} \right) + \frac{(c_w - c_{p1})}{(c_{p1} - c_{p2})} \left(\frac{c_{p2} - c_1}{c_{p2} - c_2} \right) \right] \left(\frac{c_2 - c_2}{c_{p2} - c_2} \right) \quad (5)$$

Equation (5) indicates the increasing complexity of the relationship between wash and surface concentrations with increasing distance from the wash.

Simplified Dilution Calculations--Simplification of the detailed mass balance approach described above was required for practical application. A simplified schematic description of a typical bay segment, Figure 8-53, was developed. Basic features of the system are retained. Inward surface flow, Q_s , originates from the background region at, Q_b , where the concentration is c_b . The high input concentration, c_w , is mixed from below at a low rate, Q_m .

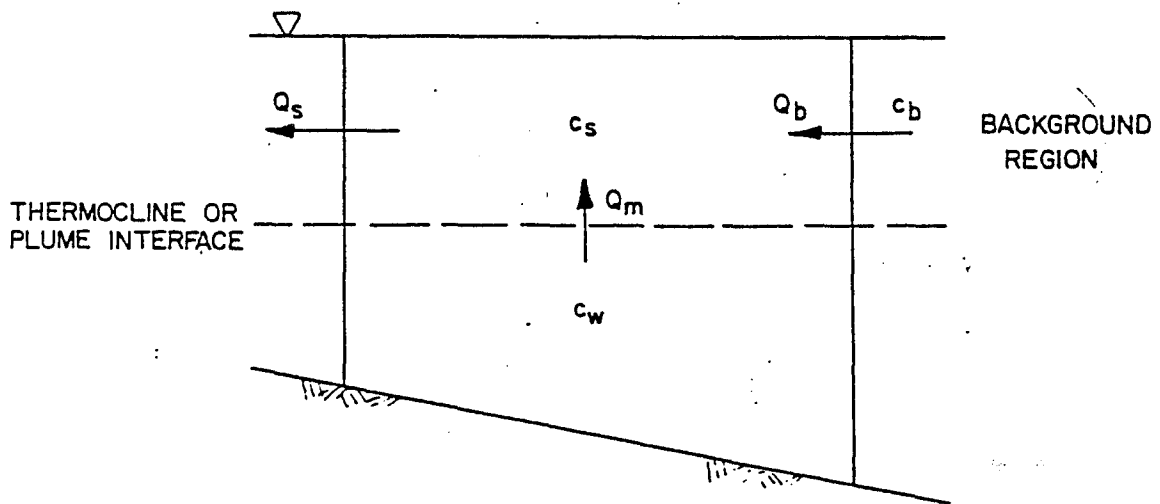

Figure 8-53 Simplified Bay Surface Layer Dilution Schematic

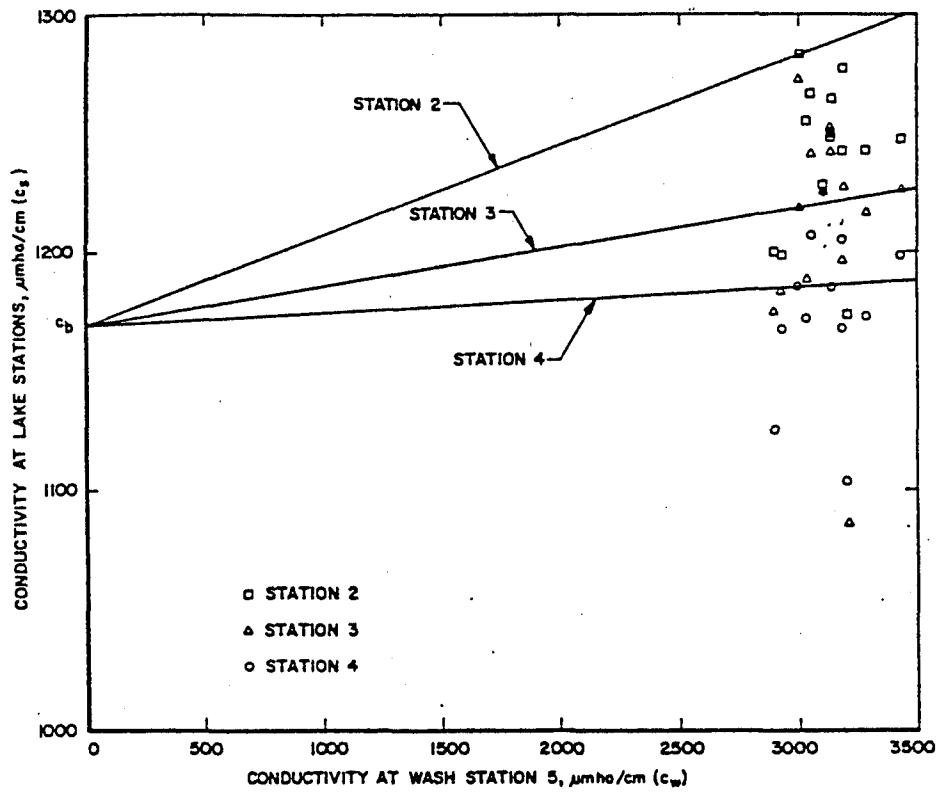

Figure 8-70 Bay Surface Concentrations, Stations 2, 3, and 4, Versus Wash Input Concentrations, Specific Conductance

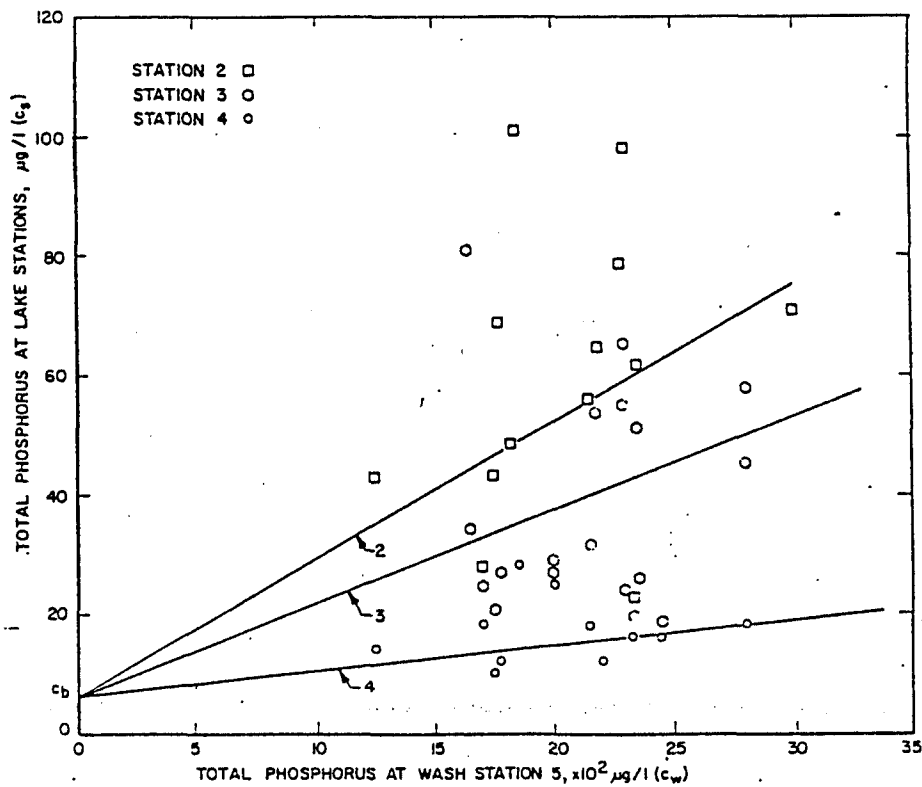

Figure 8-71 Bay Surface Concentrations Versus Wash Input Concentrations, Total Phosphorus

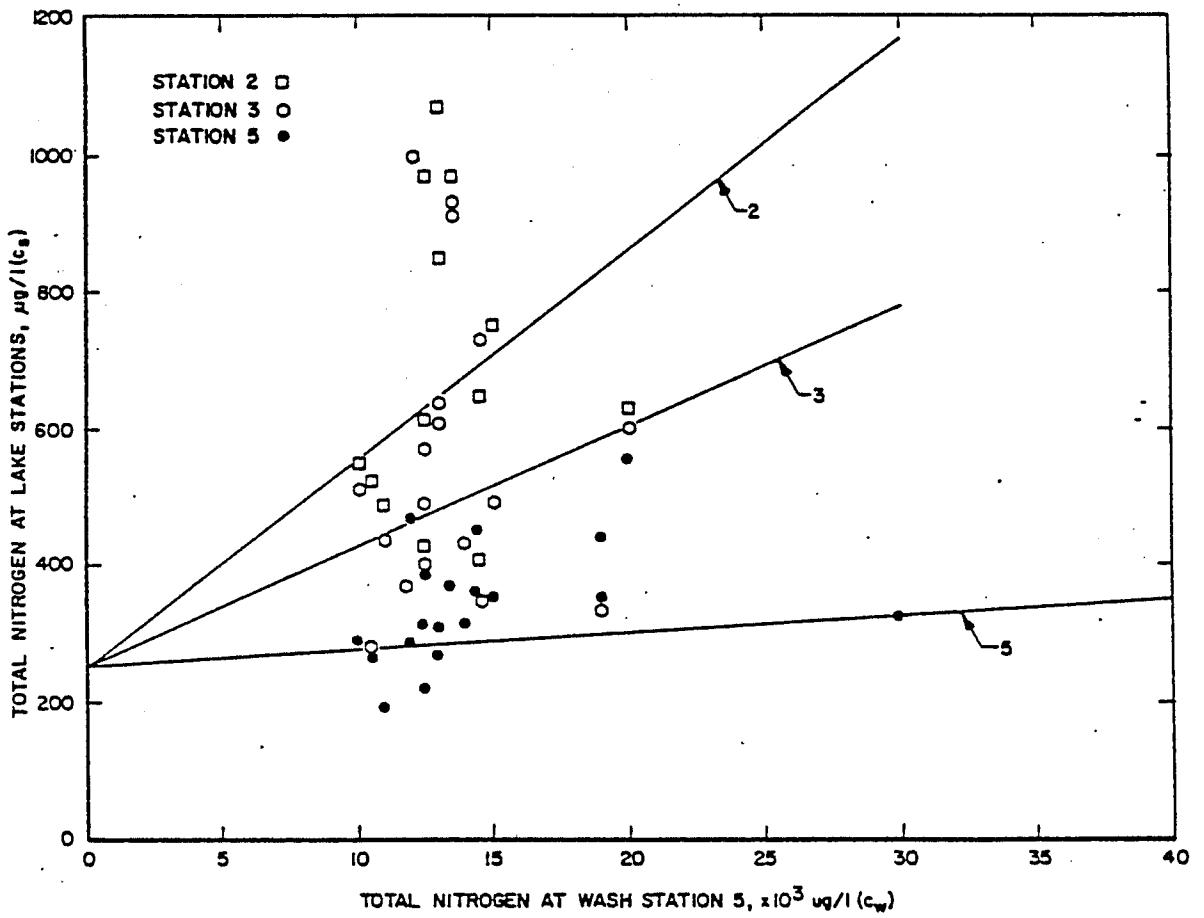

Figure 8-72 Total Nitrogen Surface Concentrations, Stations 2, 3, and 5, Versus Wash Input Concentrations

8-154

**Table 8-23. Wash Input Distribution Correlation Statistics,
May to September 1979 and 1980**

Station	Specific conductance, r^2	Total P, r^2	Total N, r^2
2	0.65	0.37	0.38
3	0.64	0.30	0.30
4	0.16	0.23	—
5	—	—	0.05

Cumulative frequency distributions of dilutions computed from specific conductance data are summarized on Figure 8-73 for Stations 1 through 5. The means and ranges of dilution values observed at Stations 1 through 5 are summarized on Figure 8-74. The data show a uniformly increasing trend of dilution with increasing distance from the wash. The mean dilution was approximately 13/1 at Station 1, increasing to approximately 30/1 at Station 2, 40/1 at Station 3, nearly 70/1 at Station 4, and greater than 80/1 at Station 5. The large number of observations in the data sets contribute to relatively narrow confidence intervals for calculated dilutions. Mean dilutions at adjacent stations were significantly different at the 90 percent confidence level or better (Student's t test, 2-tailed) except for Stations 4 and 5, as shown in Table 8-24.

**Table 8-24. Interstation Confidence Intervals for Geometric
Mean Dilutions from Specific Conductance**

Stations	n	\bar{x}	Confidence interval, percent
1	21	13	95
2	22	29	90
3	23	42	90
4	20	68	50
5	22	84	

Appendix F



May 1, 1987

Dr. Jerome Horowitz
City Hall - Dept. 9
400 E. Stewart Ave.
Las Vegas, NE 89101

Dear Dr. Horowitz,

In reference to our conversation, enclosed you will find a Preliminary Cost Proposal, a technical write-up, and a few examples of our work related to this project.

The price estimate is based on a starting time of March 1, 1988. The required instruments would be procured, tested in our laboratory for proper operation and calibration, and then shipped to the site of monitoring. About March 15, the stations would be constructed and the instruments deployed with April 1, 1988 being the starting time for monitoring.

The seven monitoring stations will be placed in a 12 km-long line, starting at the depth of 10 meters and ending at the depth of 50 meters. The instruments will be deployed in a taut mooring system that flexes freely under external forces, but maintains its initial orientation. In Figure 1, is a schematic of a typical installation. The two shallow-water stations will have instruments in 5- and 10-meter depths and the other seven stations will monitor levels of 5, 10 and 15 meters below the surface.

The vertical orientation of the instruments will be secured with plastic spheres which provide buoyancy in each level of instruments and at the top of the installation. Total buoyancy must be great enough to keep the array vertical but not enough to allow the anchor to twist or walk sideways. For the anchor, we are suggesting utilizing used locomotive wheels, which are relatively inexpensive yet do exhibit excellent stability due to the ratio between size and weight. The stations will not be visible at the surface. The lowest point of the upper part of the station set-up will be at minimum 3 meters below the water surface.

The location of all seven stations will be accomplished by using the MOTOROLA Mini-Ranger positioning system. The microwave system consists of a shipboard console which interrogates two shore stations placed on known positions (bench marks). The shipboard unit converts

the time delays between the interrogating pulses and the replies, to a distance which is displayed on its console. The accuracy of this system is +2 meters, which assures very precise locations of each station for future analysis, deployment and recovery. In addition to the above, each station will be equipped with an underwater Acoustic Pinger to enable the diver to home in on each station without losing time. The Pinger operates at 37 kHz frequency with a range of 1000 meters and has a four-month battery life. The unit emits 10-ms pulse at the rate of one per second. The diver is equipped with a Pinger Receiver which visually guides him to the station.

The enclosed technical brief fully describes the instrument specifications, data acquisition, calibration and verification.

During the monitoring period starting April 1, 1988 and ending October 31, 1988, the stations will be visited by our technical crew every three weeks. During the visit, one by one, all instruments will be removed from the mooring, stored data will be accessed and dumped into a portable computer on board the boat. The battery pack will be replaced with new or recharged batteries. The instruments will be inspected to prove that the instrument was properly operating during the last deployment. Providing that all the inspection checks and routines are acceptable, the unit will be placed back on the station for the next three-week deployment.

In our Preliminary Cost Estimate, we are proposing the following instruments:

- 19 Conductivity/Temperature CTD-12
- 19 Current Meters S-4
- 1 Current Meter S-4 with Pressure Sensor
- 7 Acoustic Pingers 37 kHz
- 7 Monitoring Stations

In order to have wave information to correlate with and help interpret other data, we are proposing to use one S-4 current meter with a pressure transducer as a wave climate meter. This instrument will indirectly record surface wave height by sensing pressure changes due to passing waves. This meter will be added to a string of instruments at a 25-meter depth. An example of the wave climate data is included in the Appendix.

The wind speed and direction should be recorded during the monitoring period in order to correlate the data with currents and wave climate. Therefore, we propose using a simple, solid state wind recording system using EPROM as a recording media. ECO-M developed this system many years ago and hundreds of instruments were built and used in the field for measuring various parameters. (See enclosed technical paper "SPIE 1985" and ECO-M's brochure).

The Cost Proposal includes processing all collected data into a data base, editing and converting it into engineering units, and plotting the results with computer graphics and XY plotters. The monthly deliverables will consist of the following items:

- a. Raw Data File
- b. Edited Data File
- c. Conversion to Engineering Units
- d. Time-Series Plots
- e. Spectral Analysis Plots
- f. Current Vector Plots
- g. 3-D Diagrams of Wave Energy
- h. Monthly Progress Report

The format and the presentations from above will have to be negotiated. We would like to confirm to your inputs.

We are hoping that this brief preliminary proposal will satisfy your requirements. Please do not hesitate to call on us if you need additional information. We will be glad to visit you at your convenience and show you examples of our work with plumes, CTD-12 and S-4 instruments and also a few of our final reports to other contractors.

Please let us know when you are free for us to visit. We look forward to hearing from you in the near future.

Sincerely,



Karel F. Zabloudil

KFZ/gf
Encls.

PRELIMINARY COST PROPOSAL

MONITORING IN LAKE MEAD NE.

DIRECT CHARGES :

TASK	1. MOBILIZATION 3/1 -3/15.	4050	
TASK	2. SITE PREPERATION 3/15-3/31	38685	
TASK	3. DEPLOYEMENT 4/1	1800	
TASK	4. DATA COLLECTION AND INSPECTION 4/1-10/31	60833	
TASK	5. DATA PROCESSING 4/25-11/2	99725	
TASK	6. DEMOBILIZATION 11/15	7140	
TASK	7. FINAL REPORT 31/12	7500	219733

INDIRECT CHARGES :

HARDWARE FOR 7 STATIONS	15000	
DIVING SUPPLIES	1800	
PARTS AND SUPPLIES	3750	
SUPPORTING SET OF SPARES	7800	
FREIGHT AND TRANSPORTATION	1800	30150 24988

MONTHLY LEASE RATE

CURRENT METERS S-4 19 UNITS	23545	
CONDUCTIVITY METERS CTD-12 19 UNITS	17818	
CURRENT METER W/PRESSURE S-4P 1 PC	1569	
WEATHER STATION	492	43424
LEASE FOR PERIOD 3/1-11/15		347392 34739

PRICE FOR INSTRUM.WHEN PURCHASED:

S-4 CURRENT METER	10327
CTD-12 CONDUCT.METER	7815
S-4P WAVE CLIMATE	13079
WEATHER STATION	4100

PRICES ARE CALCULATED FOR DELIVERY IN 1988.

SEVENTY (70) % OF LEASE PRICE ARE APPLICABLE FOR PURCHASE.

EDD SYSTEMS

MANAGEMENT ASSOCIATES INC

531 ENCINITAS BLVD, SUITE 119, ENCINITAS, CA 92024 • 619-436-2594

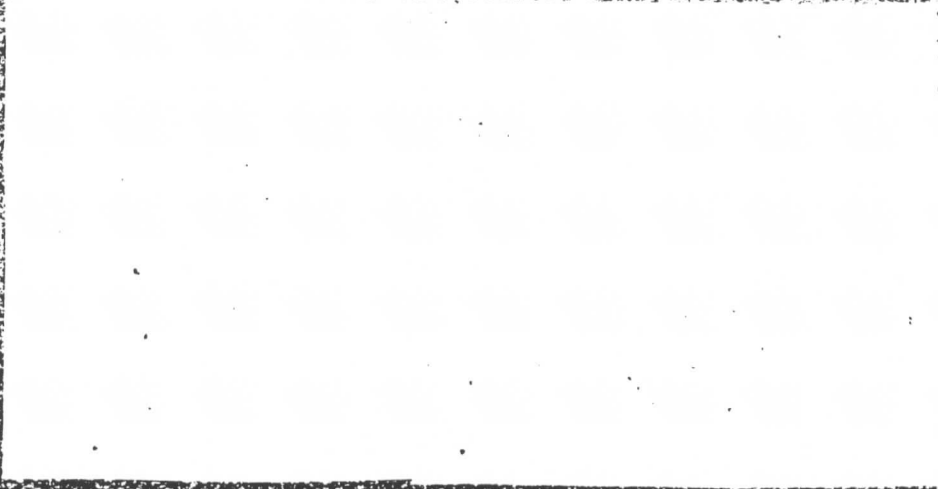

ENGINEERING & CONSULTING • OCEAN SYSTEMS & RESOURCES MANAGEMENT
GEOLOGY & GEOPHYSICS • PHYSICAL OCEANOGRAPHY • MARINE BIOLOGY

MONITORING STATIONS IN
LAKE MEAD, NEVADA

A TECHNICAL DESCRIPTION

PREPARED BY: ECO-SYSTEMS MANAGEMENT ASSOC., INC.
531 ENCINITAS BOULEVARD
ENCINITAS, CA 92024

TABLE OF CONTENTS

1. Introduction to ECO-Systems Management Assoc., Inc.....	1
2. Current, Conductivity and Temperature Measurements: Technical Discussion	2
2.1 Current Measurement Instrumentation	2
a. Equipment Specifications	2
b. System Operation	2
2.2 Conductivity, Salinity, and Temperature Measurement Instrumentation	3
a. Equipment Specifications	3
b. System Operation	4
2.3 Power Supply	5
3. Technical Discussion of Data Acquisition and Processing Systems	6
3.1 Data Flow	6
3.2 Software	6
4. Equipment Calibration and Data Verification.....	12
4.1 Water Sample Collection and Analysis	12
4.2 Routine Current, Temperature and Depth Measurement	12
4.3 Calibration of STD-12 Meter	12
4.4 Calibration of S-4 Current Meter	13
4.5 Instrument Cleaning and Battery Change	13
a. Instrument Redeployment	14
b. Standby Instruments	14
5. Mooring System	14
5.1 Design	14
5.2 Inspection	14
5.3 Cleaning and Maintenance	14
6. Appendix A	16
7. Appendix B	22
List of Figures	25

1. INTRODUCTION TO ECO-SYSTEMS MANAGEMENT ASSOC., INC.

ECO-Systems (ECO-M) began 22 years ago in La Jolla, CA. Today it is a company completely oriented toward serving the interest of those who have needs in the marine and estuarine environments.

Early on, ECO-M did the original design concept and instrumentation development for free fall sampling systems for manganese mineral exploration in the deep ocean. Extensive engineering work was also done on the development of implosive anchoring systems. In addition, geophysical projects were undertaken for mineral exploration, pipeline route surveys, and harbor development which required the development of state-of-the-art systems to meet unusual site conditions. During this period ECO-M acquired a "can do" reputation for difficult projects. As an example, contracts utilizing specialized sonar techniques to track refuse dumping plumes at sea and the definition of areal distributions of giant kelp forests required the development of unusual geophysical systems. The design of marine coring equipment, such as boxcorers and vibrocorers, was engineered and used by ECO-M staff in remote areas of the world. In more recent years many sophisticated state of the art electronic data gathering and navigation systems have also been created by our staff. As an example ECO-M was certainly one of the very first to utilize solid state data recording in its monitoring instrumentation and is probably the only private firm in the world that has its own sea going auto-analyzer system for seawater analysis.

Presently ECO-M is the prime contractor to the Marine Review Committee (MRC) which is the organization responsible to the Coastal Zone Commission of the State of California for the monitoring of the environmental impacts of the San Onofre Nuclear Generating Station (SONGS) on the near coastal environment. Our staff has conducted a constant monitoring effort at this site for the past seven years collecting information on waves, currents, light irradiance, seston accumulation, temperature and tides. In addition, ECO-M regularly collects and analyzes water for nutrients, salinity, and chlorophyll as well as sediment samples for the analysis of particulate organic carbon and nitrogen.

ECO-M has office, laboratory and work shop facilities adequate to support this project. They consist of 6000 sq. ft. of office space, 600 sq. ft. of chemical laboratory space, 800 sq. ft. of electronic shop, 300 sq. ft. of machine shop and 1500 sq. ft. of equipment preparation and storage. Within these facilities, we conduct report preparation, map and chart production, data synthesis, computer operations, equipment development, repair and maintenance, and related tasks.

In addition, we have many computers devoted to various functions from accounting to data preparation. We are also

hardwired to a shared on the premises IBM 4341 main frame system containing a word processor, a 6670 laser printer, several 3278 terminals, and an HP7221T x-y plotter. With this system we maintain a large data base of over 30×10^6 data points.

2. CURRENT, CONDUCTIVITY AND TEMPERATURE MEASUREMENTS: TECHNICAL DISCUSSION

2.1 Current Measurement Instrumentation

a. Equipment Specifications

We propose that the Inter-Ocean model S-4 current meter is the most suitable instrument available for this project. The S-4 is an electro-magnetic spherical current meter that is about the size of a basketball. It is self-contained, has no protruding sensors or external moving parts, resulting in a low-drag instrument that is easy to deploy, maintain, and recover. It is well suited for taut line moorings to depths of 1000 meters (see Appendix A for S-4 manufacturers specifications).

The S-4 housing is fabricated from glass-filled cycloaliphatic epoxy which has high strength, is dimensionally stable and corrosion proof. The exposed metal is titanium, making up the load bearing shaft and sensor electrodes. This combination of materials provides excellent protection against corrosion.

Currents are measured by creating a magnetic field and sensing the voltage induced by the movement of water through the field. Current vectors can be measured at programmable intervals and vector averaged immediately, i.e. north and east components of the current are computed and stored. Data are recorded in a non-volatile solid state memory at established intervals. Retrieval of data is accomplished through a serial port in the current meter by using a portable computer.

ECO-M began using the S-4 current meters about four years ago. To date, we have successfully logged over 50 months of current meter use with eight units. Early in our operations with this newly marketed instrument, we experienced 10-20% operational data loss due to internal software "bugs" and in some related operational problems. These problems have been solved by Inter-Ocean and ourselves. Today, data recovery is consistently above 90%.

b. System Operation

The S-4 can operate in continuous mode for 90 days using Lithium batteries. With this approach continuous averages of the two components of the current are maintained by the instrument; then for a given time period an averaged figure is recorded in memory. Several recording rates can be chosen as well as a burst

sampling option. If memory is inadequate on the standard unit, memory modules can be added. We recommend for this project continuous sampling with 6 minutes averages. If so desired, data can be averaged by the S-4 as frequently as every 3 minutes. All of our data in the field are retrieved by using a portable micro-computer and software that was developed by Inter-Ocean Systems. Data retrieval requires about ten minutes and is then stored on disc to be returned to the laboratory. The micro-computer is then used to reinitialize the S-4 and data collection resumes.

Our system of deployment, retrieval, transfer, data reduction, and presentation took many months to perfect and it is this approach that we are recommending for this project.

ECO-M maintains its own electronics shops where routine maintenance will be performed. However, since we were an early and large purchaser of the S-4 system our rapport with the manufacturer is very good and we can achieve quick turnaround for any factory calibration should any repairs or alterations be necessary. It is also beneficial for these purposes that we and Inter-Ocean are both located in the San Diego area.

2.2 Conductivity, Salinity, and Temperature Measurement Instrumentation

a. Equipment Specifications

The equipment proposed for measuring conductivity, temperature and light is a miniature "Salinity, Temperature, Depth" Probe (Model STD-12) manufactured by Applied Microsystems, Inc. The STD-12 is a small, easy to deploy instrument, ruggedly constructed of 6061-T6 aluminum, with other external fittings of 316 stainless steel. The aluminum parts are hard anodized and protected with antifouling epoxy paint. The physical size is 4" (10.2 cm) diameter, and 26.8" (67.5 cm) long. A sacrificial zinc anode is attached to ensure season after season of corrosion free operation.

The "Temperature" sensor is a fast response microbead thermistor mounted in a stainless steel capillary tube, designed for pressure insensitive measurements. Special laboratory aging technics ensure repeatable measurements within $\pm 0.01^{\circ}\text{C}$ over a range of -5 to $+35^{\circ}\text{C}$ for periods exceeding one year.

A patented "Conductivity" sensor, manufactured by Applied Microsystems, is another feature designed into the STD-12. This four electrode device demonstrates excellent long-term stability, and high precision in areas of extreme fouling. Careful design considerations in both the electrode positioning and excitation circuitry results in the cell having wide dynamic range; ie. from distilled water to 50 ppt salinity. The accuracy of the

conductivity measurements are $\pm .01\text{mS/cm}$ and resolution $\pm .003\text{mS/cm}$.

The instrument is powered with internal batteries. The STD-12 draws 43 mA during sampling and 9 mA during standby. With a 15-minute sampling rate, the internal batteries can provide up to 80 days of operation.

Data are collected in a solid state memory of 60K RAM. Seven thousand six hundred forty-eight scans will be stored per deployment. Output/input and power-up is accomplished via two "double contact" underwater connectors. Communication with the on-board computer is provided with an adaptor for conversion to standard RS-232A format data. However, the signal from the instrument to the adaptor requires only two polarity independent wires. A copy of an Applied Microsystems Brochure is provided. It includes the complete STD-12 specifications (see Appendix A).

b. System Operation

The STD-12 has the option of logging continuously or logging at user chosen time increments. (For this project, we propose to use a 15-minute sampling interval for continuous monitoring and logging on request when connected to the on-board computer or terminal. This log-on-request is very useful during system checks and calibrations.) The STD-12 permits the user several modes of operation. These are selected through user commands, and by switches inside the instrument. The STD-12 can be set to one of the following four modes:

1. Computer or terminal operation
2. Calculation of the measured parameters done internally or externally by the user
3. Allows user to select Baud rate
4. Sets intermittent or continuous operation

Mode #2 (above) will produce the following output per scan.

1. Instrument number (in digits)
2. Time code (from start with a range of 0 - 65535)
3. Pressure in dB x 10 (if pressure sensor is used)
4. Temperature (in $^{\circ}\text{C} \times 1000$)
5. Conductivity (in microSiemen/cm)
6. Salinity (in parts per thousand)
7. Velocity of sound (in meters/second x 10)
8. Carriage return/Line feed (EOL)

The STD-12 uses an 1802 CPU and a 4 1/2 digit ADC (Analog/Digital Converter). Data from the sensors are rapidly digitized and transmitted to the terminal upon request. To obtain engineering values for measurements, a floating point routine performs calculations as follows:

CONDUCTIVITY - conductivity ratio (R) is calculated from the following formula: $R = A + BN_r + CN_r^2 + DN_r^3$.

A, B, C, and D are calibration coefficients, which are determined at the factory.

N_r = raw value for the conductivity ratio,
as measured by the STD-12.

Conductivity - $C = R \times 42.921 \text{ mS/cm}$

TEMPERATURE - $T = A + BN_T + CN_T^2 + DN_T^3$

N_T = raw value for temperature
as measured by the STD-12

A, B, C, and D are calibration coefficients, which are determined at the factory.

PRESSURE - $P = A + BN_p + CN_p^2 + DN_p^3$ d Bars

N_p = raw value for pressure
as measured by the STD-12

A, B, C, and D are calibration constants.

SALINITY - Salinity is not measured directly, but is calculated using a pressure, temperature and conductivity ratio, from the Practical Salinity Scale, 1980 formula.

The velocity of sound can be calculated from pressure, temperature conductivity, and salinity, using Wilson's formula.

The STD-12 is warranted by Applied Microsystems against defects in workmanship and materials for the entire life of the instrument.

2.3 Power Supply

The batteries inside the instruments are capable of operating the instruments for about half of the entire deployment period.

3. TECHNICAL DISCUSSION OF DATA ACQUISITION AND PROCESSING SYSTEMS

3.1 Data Flow

The block diagram in Figure 1 is a schematic of our proposed data flow from the field instruments to final data diskettes. Components along the flow path consist of standard off-the-shelf units and interfacing cables which have been well tested and proven over the years. Spare parts and replacement units are easily obtainable. Software necessary at the various stages of data flow has been developed and used continually at ECO-M over the past two years and is very reliable.

As shown in Figure 1, data is transferred from the S-4's and STD's serially to the portable field computer, an IBM PC or compatible unit. They are the most adaptable for this purpose. The data is then stored on diskettes which in turn are taken to the main laboratory where the data is transferred to the main computer, converted to engineering units, plotted and reviewed for quality. Hardcopy plots and printout are then produced and provided to ECO-M staff scientists for evaluation. They include time series, velocity vector and spectral analysis plots (Figure 2). Upon approval raw data files and processed data files will be transferred to diskettes for distribution. A 5 & 1/4" floppy disk IBM PC compatible will be used.

3.2 Software

As part of the system, we will use two data retrieval programs that convert data to engineering units and provide tabular and graphical output on either a screen for immediate review or as hard copy for archiving and later review. A flow-chart summerizing the basic steps of these programs is shown in Figure 3.

The first program is a software package developed by Inter-Ocean to support the S-4 current meter. It is entitled "Current Meter Program (CM-P)". A sample output from this program is shown in Figure 4.

The second program, developed by ECO-M, is called "Conductivity, Temperature and Depth Program (CTD-P)". It is similar to the CM-P software. The CTD-P Program displays the data in engineering units, e.g., Temperature in C^o, depths in meters, conductivity in mS/cm. In addition CTD-P will caculate salinity in ppt and density.

The output of these two programs will provide all the necessary information for currents, conductivity, temperature, salinity, and depth as a function of time at the locations specified in this project.

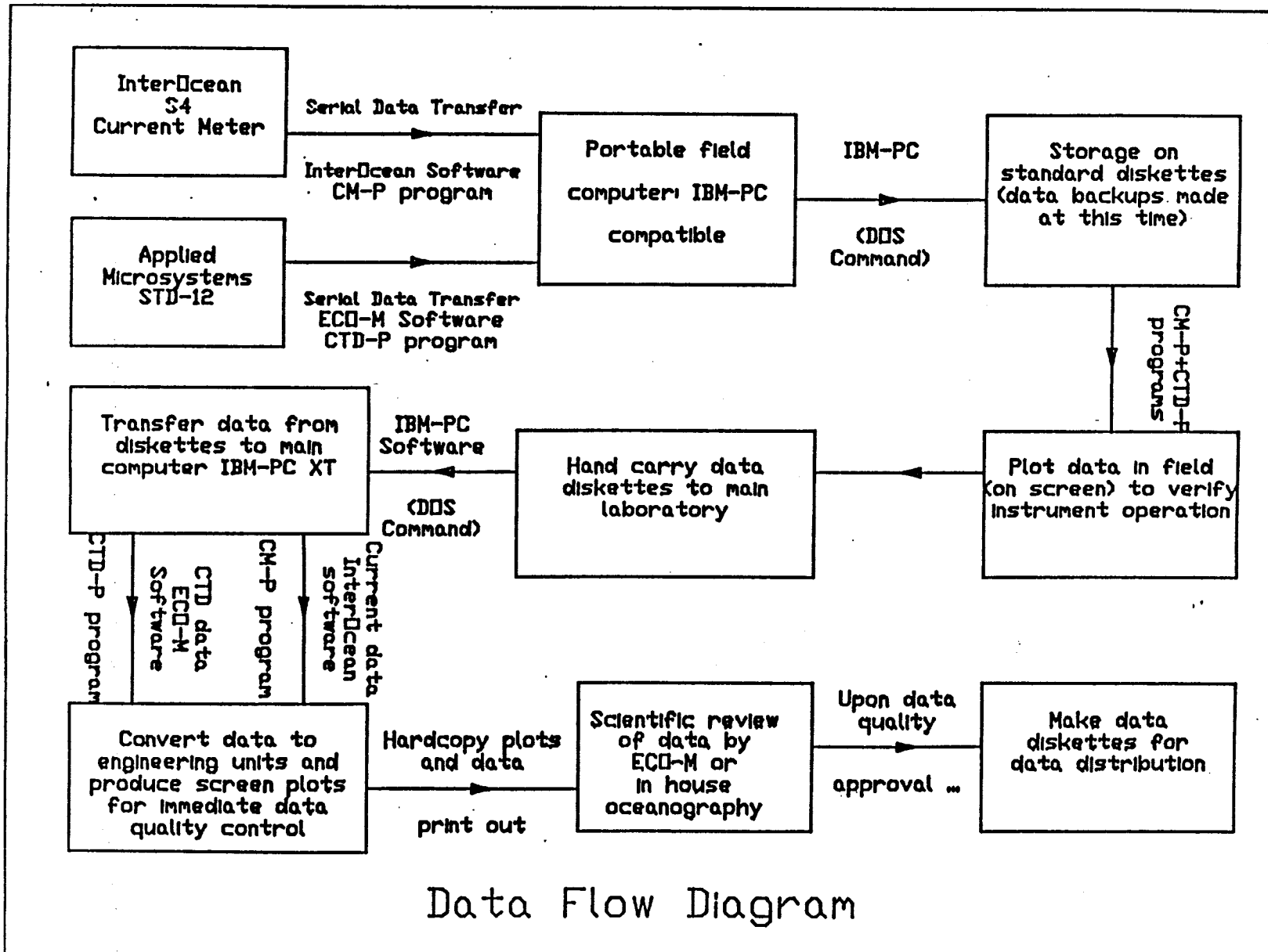

Data Flow Diagram

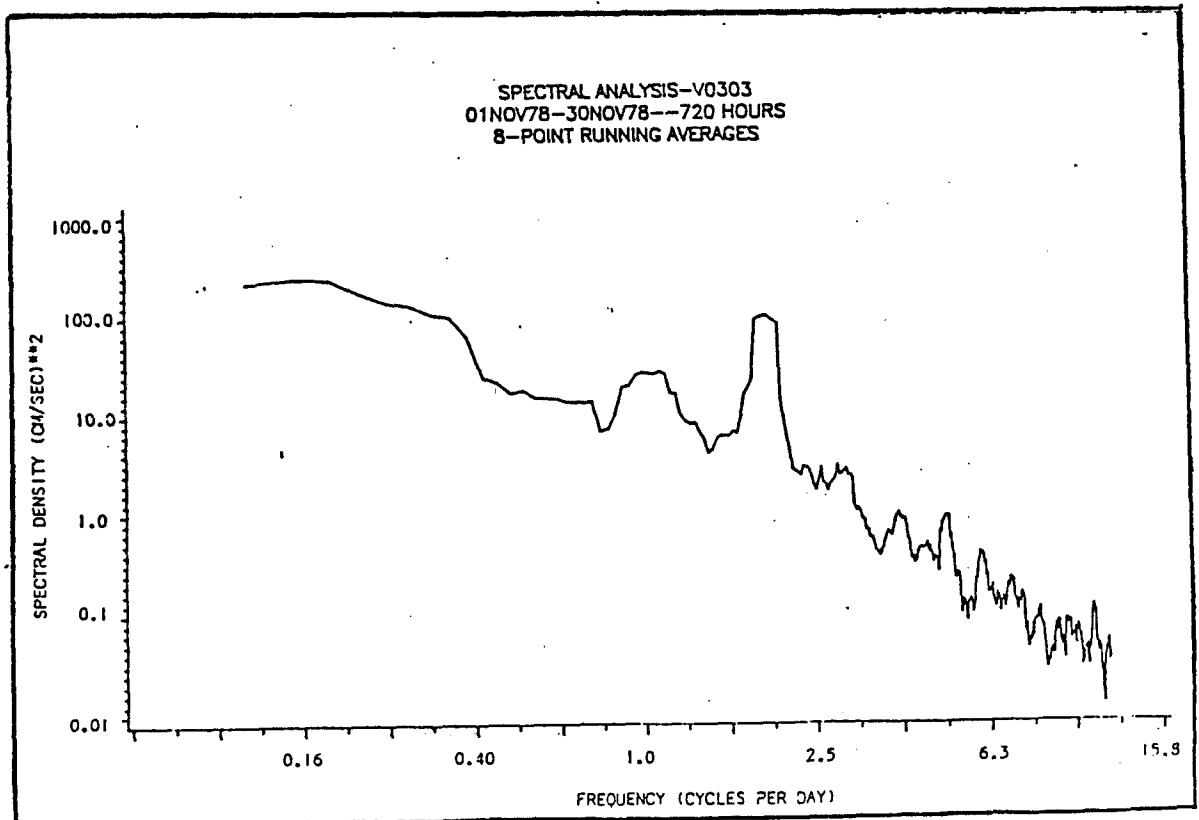
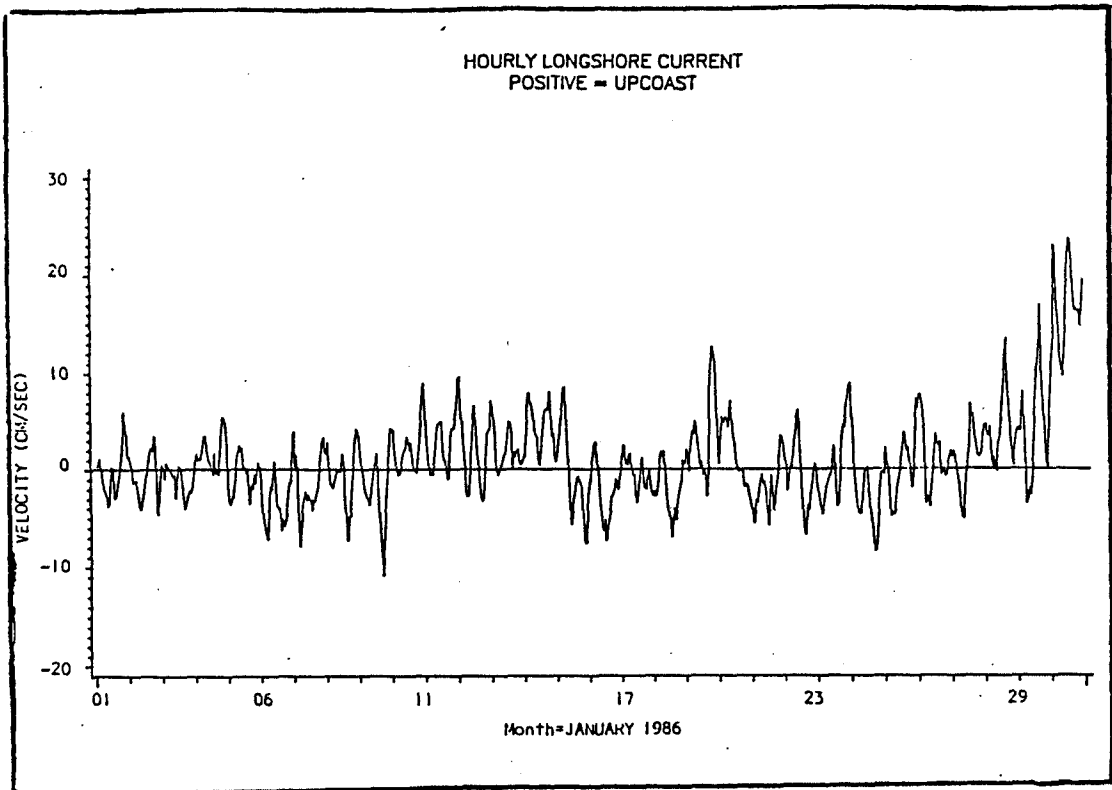
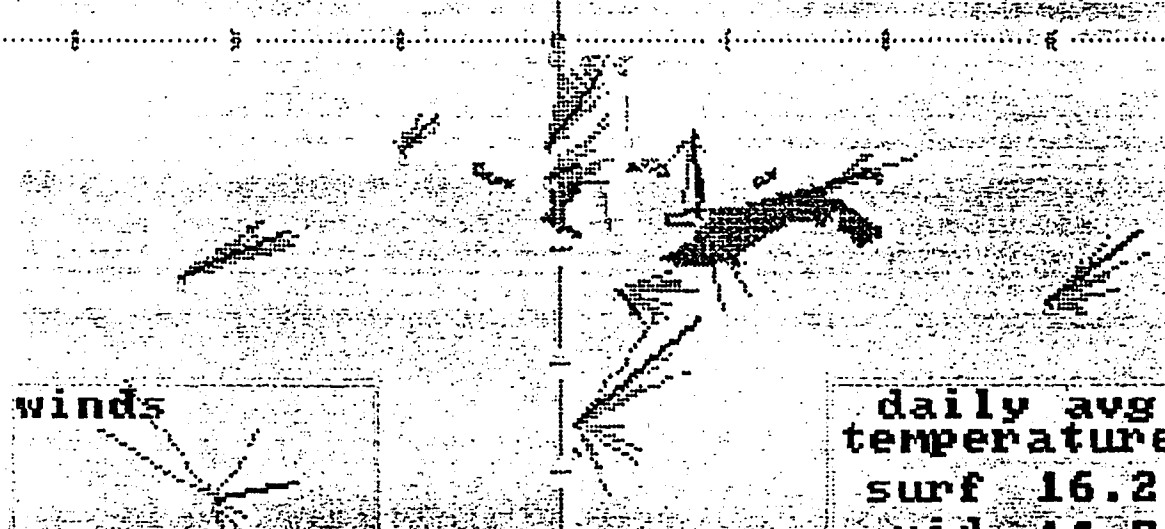

Figure 2a.

scale =  wave ht = .8 mts
10 cm/sec-currents 4 pumps-unit 2
5 knots-winds SONGS 3 pumps-unit 3

kelpmar86



winds



daily avg
temperature
surf 16.2
mid 14.7
bot 14.9

01JAN86 00:00
01JAN86 13:30

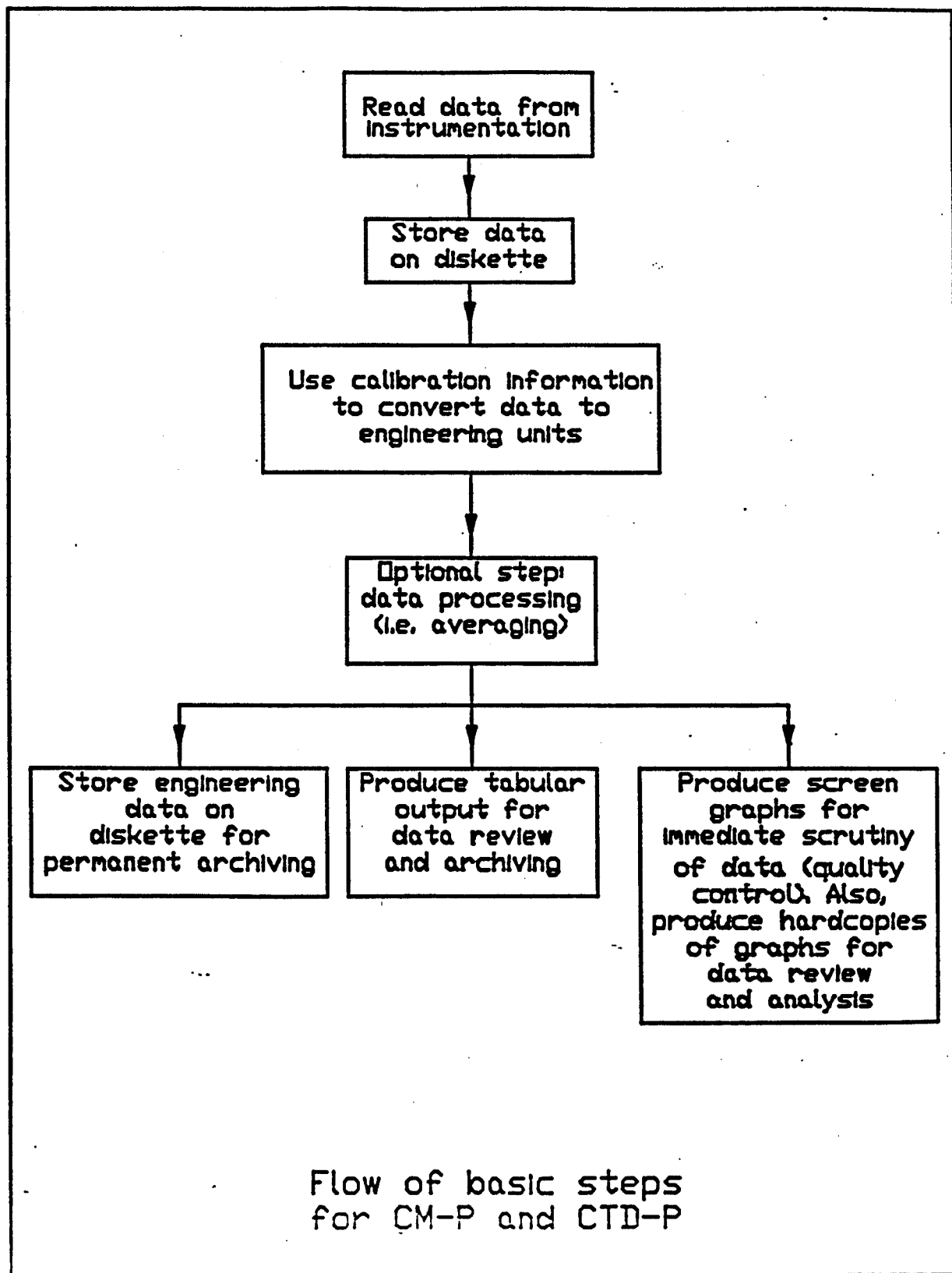

4. EQUIPMENT CALIBRATION AND DATA VERIFICATION

4.1 Water Sample Collection and Analysis

Water samples will be taken at the site of each meter to verify the measurements. These samples will be transported back to the laboratory and analyzed using the standard methodologies noted below.

1. Conductivity and Salinity: These parameters will be determined using known potassium chloride solution and standard water. The accuracy for conductivity is $\pm .01$ milliSiemens and for salinity is $\pm .005$.

2. Cations: Calcium, magnesium, sodium, and potassium will be analyzed by Direct Aspiration Atomic Absorption as per EPA methodologies 215.1, 242.1, 273.1 and 258.1.

3. Anions: Bicarbonate and carbonate will be determined from pH and alkalinity measurements. Alkalinity will be measured by titration and pH will be measured using a calibrated probe. Chloride, sulfate, and nitrate will be determined using automated colormetric methodology per EPA methods 325.1, 375.2 and 352.2.

4. Turbidity and Total Suspended Solids: Turbidity will be determined nephelometrically per EPA method 180.1. TSS will be determined by APHA method 209C. ECO-M maintains its own chemical labs equipped to perform water quality, nutrient, chlorophyll, and related analyses.

4.2 Routine Current, Temperature and Depth Measurement

During each field servicing, current and surface water temperature measurement will be acquired using a Calibrated Endeco 110 Current Meter and bucket thermometer at the site of each meter. These measurements will be coordinated with real time current and temperature measurements from the monitoring equipment to determine if instrumentation is working properly.

4.3 Calibration of STD-12 Meter

Prior to field deployment, the STD-12 will be electrically "checked out" to confirm correct operation. Precision resistors are substituted for the three sensors (pressure, temperature, and conductivity) and a print out of the results is obtained. Explicit instructions for this calibration technique are provided in the reference manual for the STD-12. This procedure provides assurance that the instrument is operating correctly prior to deployment.

Inspection and calibration will consist of the following procedures:

- a. Routine preventive maintenance of electronics and mechanical parts.
- b. Replacement of all "O" ring seals, batteries and underwater connectors.
- c. Calibrations for temperature will be done using a certified high resolution Electronic Thermometer (Model 8810A DVM Fluke Inc.). Conductance will be calibrated using Standard Sea Water P79 at various temperatures for several salinities (obtained by evaporating/diluting by weight with distilled deionized water); and calibration of depth accuracy by profiling in a precisely measured water column. If an instrument fails to be accurate within the original specification, the unit will be sent to the manufacturer for recalibration and for any updating of the coefficient calibration values.

4.4 Calibration of S-4 Current Meter

Measurements from both the Endeco 110 and the S-4 meters will be compared for an inter-instrument calibration. In the event that differences between the two meters are large or unresolvable, the instrument in question will be withdrawn from the field for factory calibration.

In our experience with nine S-4 current meters continuously deployed over the past 2 years, factory calibration has not been required. The long term stability of the S-4's performance is excellent.

4.5 Instrument Cleaning and Battery Change

Upon retrieving the instruments from the water, a general inspection of their condition and that of the rigging will be undertaken. Any problems as well as a general description of their condition (corrosion, bio-fouling, debris entanglement, etc.) will be noted in a field log. This information will serve to define any problems in the system likely to cause long term difficulties and provide information that will help resolve abnormalities in the data caused by problems at the mooring (such as debris being wrapped about a sensor). Once this has been accomplished, the instruments and rigging will be cleaned.

With cleaning completed, the instruments will be opened, the charge level of the batteries noted in the log (this information provides a useful clue as to the general condition of the instrument) and new batteries installed. The charge level of the new batteries will be taken at this time and noted in the log. The technician responsible for this servicing will have a copy of the information collected during previous servicings to assist in making any decisions that may be required on the spot.

a. Instrument Redeployment

As has been discussed earlier, the data will be withdrawn from the instruments using a portable computer. After retrieval the instruments will be returned to their proper depth. A brief sample of data collected during the test will be transferred to diskette to supplement field log information.

b. Standby Instruments

We strongly suggest that at least one spare instrument of each type be used as part of this program. Should an instrument be discovered to be nonoperational a spare instrument could be used to replace it without any ensuing data loss or expense incurred for redeployment after repairs.

5. MOORING SYSTEM

5.1 Design

The monitoring stations will be located in a 12 Km line in depth of water ranging from 10 to 50 meters. The instruments will be deployed in a taut mooring system that flexes freely under external forces but maintains its initial orientation (Figure 5). Bouyancy will be provided by plastic spheres at the top of each installation. The anchors we propose are locomotive wheels, which weigh approximately 200 Kg. They are relatively inexpensive and exhibit excellent stability due to their appropriate ratio between size and weight. The installations will not be visible at the surface.

We will use a MOTOROLA Mini-Ranger as a positioning system. It consists of a shipboard unit which interrogates two shore stations placed at known locations (benchmarks). This system has a precision of +/- 2 meters. In addition, each station will be equipped with an underwater acoustic pinger to enable a maintenance diver to home in without unnecessary delay. The pingers have a range of 1 Km and a one month battery life.

5.2 Inspection

A general visual inspection of the entire mooring array will be undertaken to locate any problems such as corrosion, vandalism, damage, or wear.

5.3 Cleaning and Maintenance

Routine cleaning will encompass the entire field assembly and include any part that is deemed necessary to maintain the system in proper working order. Maintenance will be performed on as needed basis with the idea of keeping the system in top operating condition.

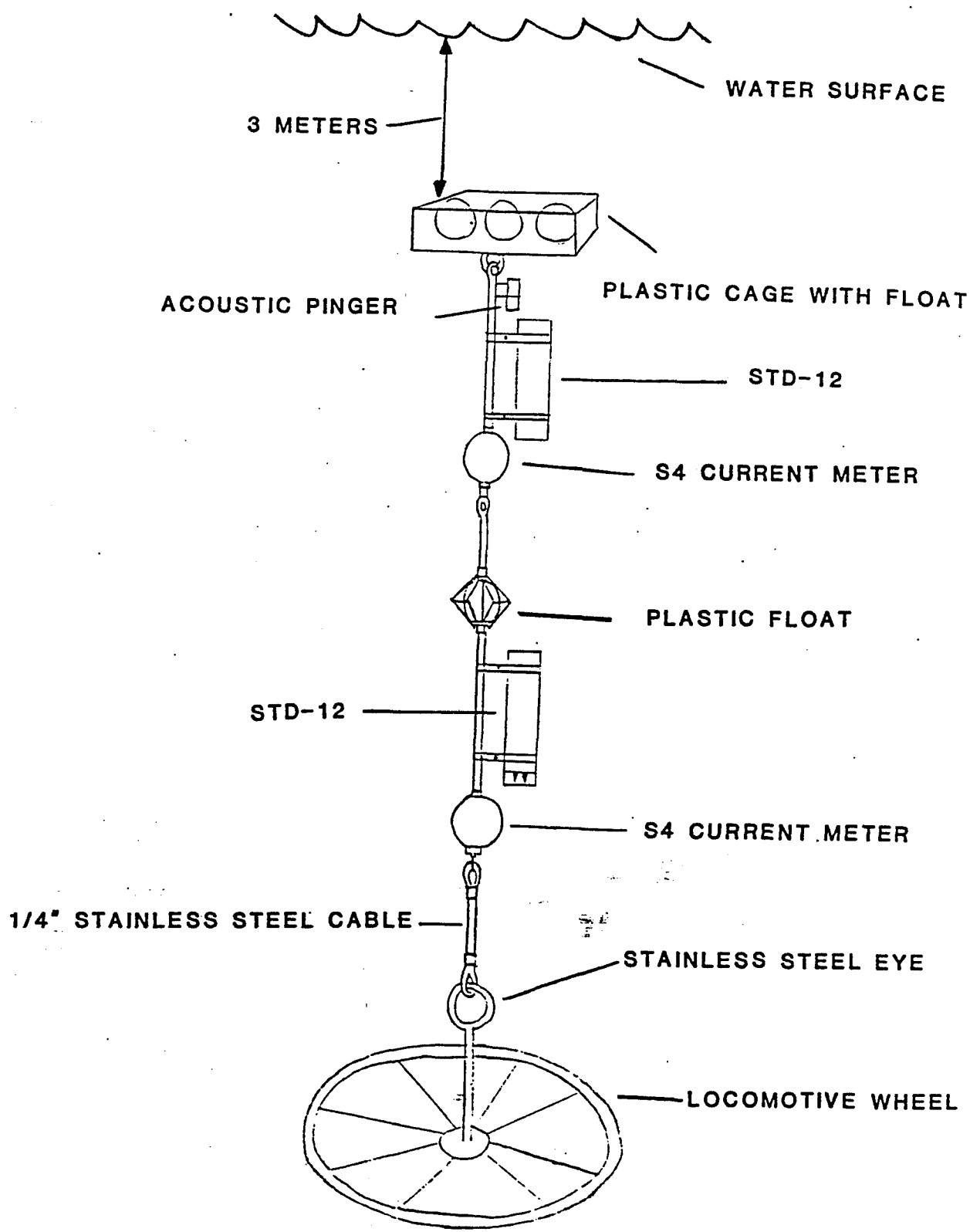
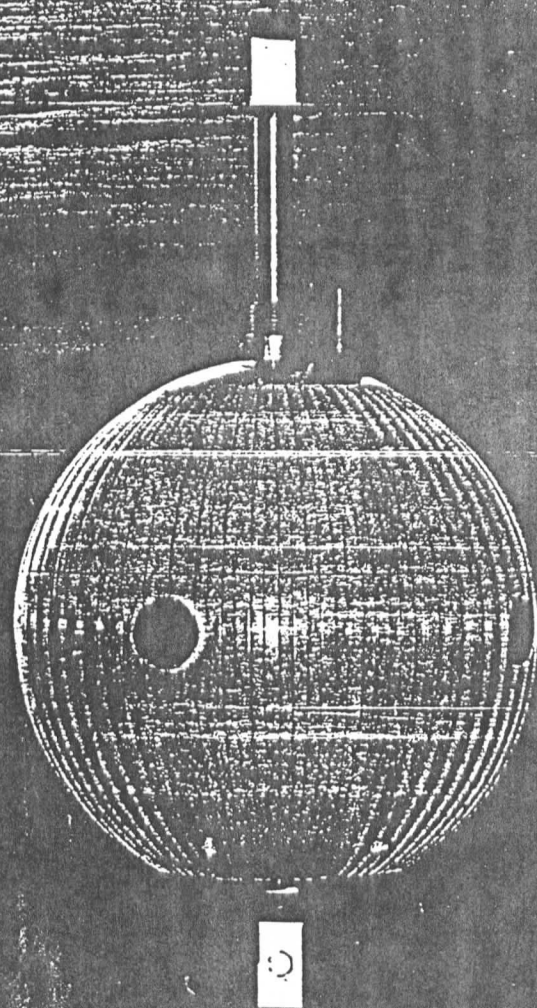

Figure 5.

APPENDIX A

CURRENT MEASUREMENT AND MUCH MORE

ADVANCED ENGINEERING
FOR RELIABILITY AT SEA



InterOcean
Systems, Inc.

3501 Ocean View Court, San Diego, CA 92123 • Tel: (619) 565-8400 • Telex: 181-701 • Fax: (619) 268-9600

SPHERICAL SOLID STATE

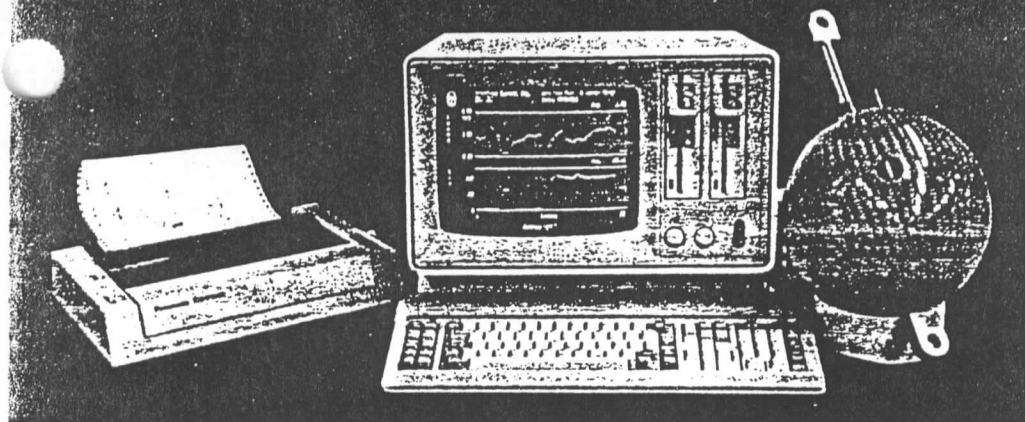

ADVANCEMENT IN DESIGN

The S4 is a truly unique instrument for water current sensing. The instrument, itself, is the self-contained current measuring sensor, enclosing all necessary solid-state electronics for acquiring, processing and outputting data.

The S4 is designed to measure the true magnitude and direction of horizontal current motion in any water environment. Water flows through the electromagnetic field created by the instrument, thereby producing a voltage (potential gradient) which is proportional to the magnitude of the water velocity past the sensor. This voltage is then sensed by the two pairs of titanium electrodes located symmetrically on the equator of the sensor. The data obtained is then stored in CMOS static RAM memory.

The simple spherical shape of the S4 is a contributing factor in the excellent rejection of vertical components of water movement, providing significant improvements in measuring currents in the wave zone. Also, because of its low threshold and low noise level, the S4 is the current meter of choice for low current regimes.

The unique grooved surface of the S4 housing produces stable hydrodynamic characteristics that ensure exceptional linearity and stability. This new hydrodynamic design, in which the instrument body itself is the source of current measurement, is a technological breakthrough. There is no mechanical motion, protruding parts or sensor support structures to interfere with the water flow pattern.

The S4 has withstood rigorous performance testing, and has produced excellent and stable data in the field.

The internal flux-gate compass provides heading information which is used

to reference the current direction to magnetic North. For fixed installations, the S4 may be operated in an X/Y orthogonal mode whereby the current vector can be referenced to true North or any other desired heading.

Adaptive sampling, user programmability, optional sensors and expandable memory permit highly selective data collection—and/or longer deployment intervals.

THE S4 HAS SOLID STATE MEMORY

Data obtained by the S4 is stored internally in solid-state, high-reliability, non-volatile memory. From this memory, data is retrieved through an RS-232-C port to the user's terminal, computer or other storage device. This eliminates lost data caused by tape or strip chart damage during deployment or after recovery, and removes the need for expensive tape readers or large numbers of tapes and chart rolls. Turn around time for data retrieval is short, so fewer instruments are needed in inventory.

The S4 microprocessor driven electronics produce unmatched accuracy, resolution and operational flexibility.

Processing of data for storage in memory and/or real-time display is instant, and retrieval is accomplished through a serial port; **there is no need to open the housing.**

THE S4 IS SOFTWARE CONTROLLED

The EPROM-formatted microprocessor affords unprecedented flexibility and simplicity of use. The low power CMOS microprocessor of the S4 performs true vector averaging, burst sampling and adaptive sampling. The

instrument can alter its recording format in response to oceanographic events. Customized programs can be developed to meet the special needs of researchers.

THE S4 IS SOLIDLY BUILT

All electronics and power necessary for operation of the current meter are contained within the compact 10 inch (25 cm) diameter sphere. This sphere is made of a durable, high strength, dimensionally stable, corrosion proof plastic. There is nothing to break or foul.

Connection to a mooring is by means of an axial **titanium** load bearing shaft. The only other metal parts in contact with water are the titanium electrodes. This combination of materials provides the user with a rugged, easy to use current meter that can take extended deployment in harsh sea water environments, without fear of data degradation due to corrosion failure or biological attack. Additionally, the chances of handling damage are minimized.

The S4 design reduces drag. Less drag allows lighter, less expensive mooring tackle to be used.

S4 APPLICATIONS

The S4 may be used in any body of fresh or salt water, and can be deployed up to 6,000 meters deep. It is particularly valuable (1) in wave zone where its excellent vertical cosine response is needed; (2) in low current regimes where exceptional stability and resolution are needed; (3) in very high flow regimes where low drag and lack of moving parts permit practical deployment without concern for fragility; (4) for long deployments where memory capacity and user programmability are needed.

Options for increased data acquisition include conductivity, temperature, depth, automatic tilt compensation, 128K byte and 256K byte memory, high speed and high resolution temperature, adaptive sampling and a lithium battery pack.

The S4 can be configured for **water column profiling** and **wave measurement**.

As a system, the S4 can provide **real-time data display** either by hard wire or radio telemetry to a base station, through line of sight or satellite link.

SENSOR CURRENT METER

S4 responses are shown in red, ideal responses in blue.

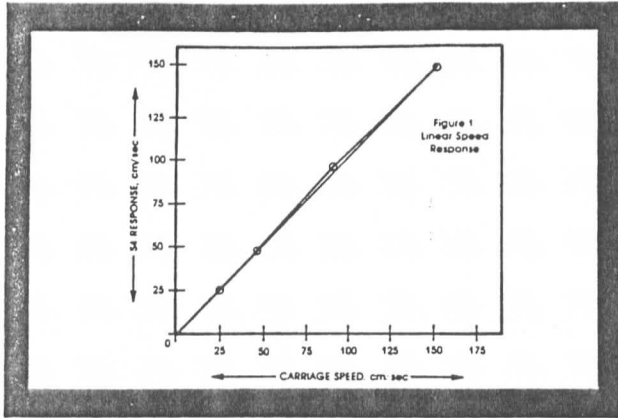

Figure 1 shows the S4 linear speed response. Earlier electromagnetic sensors have smooth surfaces. Their hydrodynamic characteristics change at certain turbulence, vibration and temperature dependent speeds, resulting in non-linear and unstable response. The unique grooved surface of the S4 produces stable hydrodynamic characteristics and ensures exceptional linearity and stability.

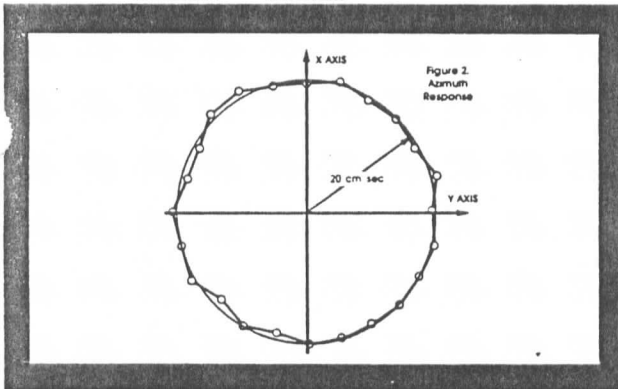

Figure 2 displays the S4 azimuth (horizontal) response in polar form. The speed error is less than 0.7 cm/sec (0.02 ft/sec), resulting in unusually accurate current measurement, unaffected by current direction.

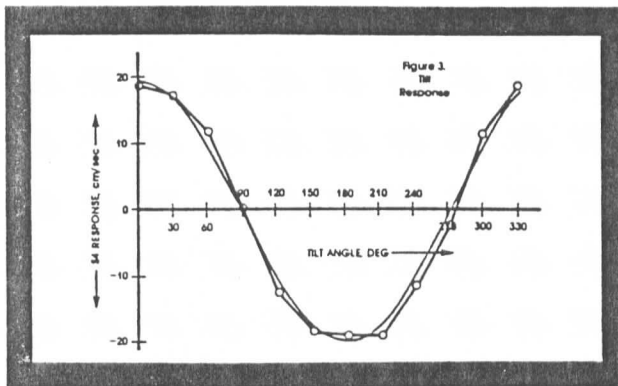

Figure 3 shows that the S4 tilt response closely approximates a cosine function, necessary for accurate performance in the presence of wave or mooring induced vertical motion. Important note: The response shown is that of the complete current meter, not simply that of a current sensor. Other current sensors demonstrate comparable responses, but their accuracy degrades when mounted to bulky and asymmetric housings.

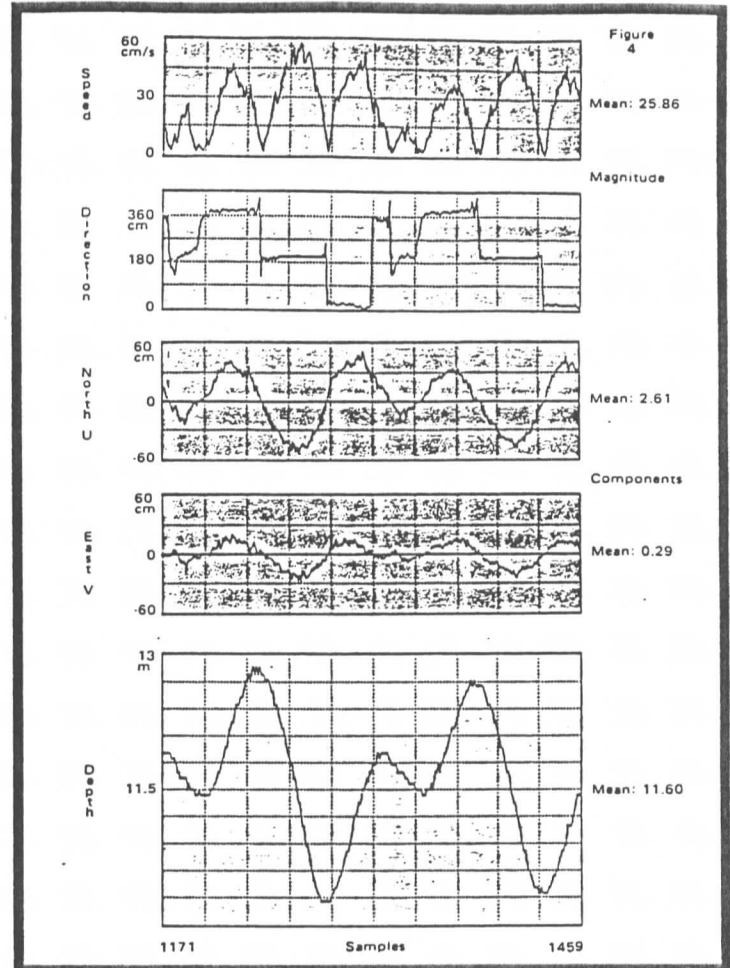
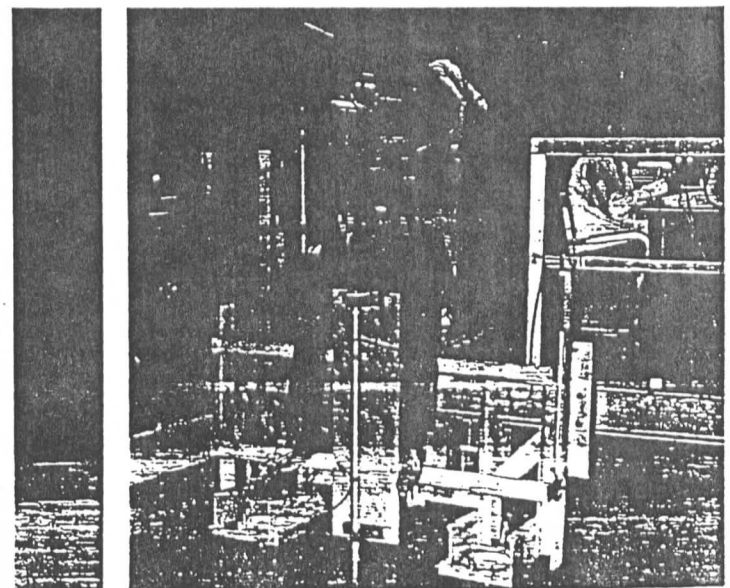

Figure 4 shows data recorded by an S4 in a bay deployment, processed using the standard InterOcean PC-S4 data reduction package. Note the clear definition of speed and direction including the event which includes the small tidal reversal, during which currents averaged less than 10 cm/sec. Note also, the high resolution depth record which can be used for accurate analysis of wave and tide events. (Data recorded as 1 minute (120 sample) vector averages every 10 minutes.)



Performance Testing being conducted at Nat'l. Space Tech. Lab.

6000 Meter S4D

Profiling S4P

Identical to the standard S4 Current Meter in all other characteristics; the deep model, S4D, is housed in a ten inch glass sphere rated to a depth of 6000 meters. Mooring tension loads are supported by a tension rod which utilizes offset arms for attachment of the current meter. Since deep sea currents are significantly less than surface currents, this model is offered in 0-50 cm/sec and 0-100 cm/sec versions which afford the user higher resolution and accuracy than the standard S4 range of 0-350 cm/sec.

The S4P is designed for rapid response CTD measurements while the instrument is used for profiling the water column as a function of depth. To support profiling work, fast response sensors are used for temperature, conductivity and depth. This model of the S4 can incorporate current measurement sensors and electronics at the discretion of the user. It incorporates all of the advanced electronics features of the S4 including high resolution, all solid state processing and data storage. Formatting and access to the data as well as interactive operator control and adaptive sampling are provided by the proven S4 electronics assembly.

SPEED SENSOR

TYPE: Electro-Magnetic, 2 Axis
RANGE: 0-50 cm/sec (0-1.64 ft/sec)
RESOLUTION: 0.03 cm/sec
ACCURACY: 2% reading +/- 1 cm/sec (0.03 ft/sec)

MECHANICAL

SIZE: Sphere, 25 cm (10 in.) dia.
WEIGHT: Air: 9 Kg (20 lbs.); Water: 0 lbs. (0 lbs.)
MOORING: Offset; maximum tension 4500 Kg (10,000 lbs.)
PAD EYES: Accepts 1.6 cm (3/8 in.) shackle
MATERIAL: Sphere, annealed borosilicate glass; pad eyes and bands, 316 SS
DRAG: 0.7 Kg (1.5 lbs.) @ 50 cm/sec
DEPTH: 6,000 M (19,200 ft.) maximum
TEMPERATURE: Storage, -40 to +50°C; operating, -5 to +45°C

All other specifications for the S4D and S4P are the same as for the standard S4

TEMPERATURE

TYPE: Platinum Resistor
RANGE: -5 to +45°C
RESOLUTION: 0.01°C
ACCURACY: +/- 0.02°C
RESPONSE TIME (63%): 60 ms

CONDUCTIVITY

TYPE: Inductive Head
RANGE: 0 to 65 mS
RESOLUTION: 0.01 mS
ACCURACY: +/- 0.02 mS
RESPONSE TIME (63%): 20 ms

DEPTH

TYPE: Semiconductor Strain Gauge
RANGE: Specify (up to 1500 psi)
RESOLUTION: 0.01% fs
ACCURACY: +/- 0.15% fs
RESPONSE TIME (63%): 60 ms

S4D

S4P

Inter Ocean
 systems, inc.

Important S4 Software Options

ADAPTIVE SAMPLING

The *Adaptive Sampling* option for the S4 allows burst mode recording of data over extended periods previously not possible due to memory limitations with normal burst mode recording. This has particular application for current and wave data recording where the user is only interested in recording high level occurrence.

Much of the recorded data, during unusually low activity, is of little interest. This low activity data consumes a large portion of the available memory. Adaptive sampling permits a threshold to be entered into the S4 before deployment. While the S4 is in the logging mode, 1200 half-second samples (10 minutes) of current speed, and depth (if enabled), are stored in a temporary buffer. The average value (vector magnitude for current speed, or wave-height for waves) for the 1200 samples is calculated and compared to the stored threshold. If the average value is less than the threshold, then the 10 minutes of data in the buffer will not be saved to memory. The S4 will power down and wait for the next programmed interval to occur. If the average value exceeds the threshold, then the 10 minutes of data in the buffer will be saved to memory as 1200 Burst Samples, and the S4 will power down and wait for the next programmed interval to occur. Special Record Blocks containing date, time and up to eight analog channels are recorded after every 120 sample (one minute) intervals during the Burst Sample.

The S4 is programmed to turn-on for ten minute periods at specified intervals when adaptive recording is enabled. The specified intervals can be from 11 minutes to 23 hours and 59 minutes.

The adaptive recording option for wave measurements requires the O-70 meter depth option to be included in the S4.



AUTOMATIC TILT COMPENSATION

The S4 responds linearly to flow normal to the axis of the sensor. If the axis of the current meter is inclined from the perpendicular to the plane of flow, such as can occur in long taut-line moorings with moderate current speeds, the sensor will respond to the component of flow normal to the vertical axis of the sensor. Numerous tow-tank tests have verified the true vertical cosine response of the S4.

When the Tilt option is included in the S4, the vertical cosine response is fully corrected for angles of tilt from 0 to 45 degrees. No external correction of the vector average data is required. This option includes a two-axis tilt sensor, electronics to condition the tilt sensor signal and additional software to process the tilt information and apply the cosine corrections to the current speed data. Although not required for external processing of the data, X and Y tilt angle data may be recorded for later retrieval. The data is on analog channels 7, and 8 and recording is available as with any of the other analog channels.

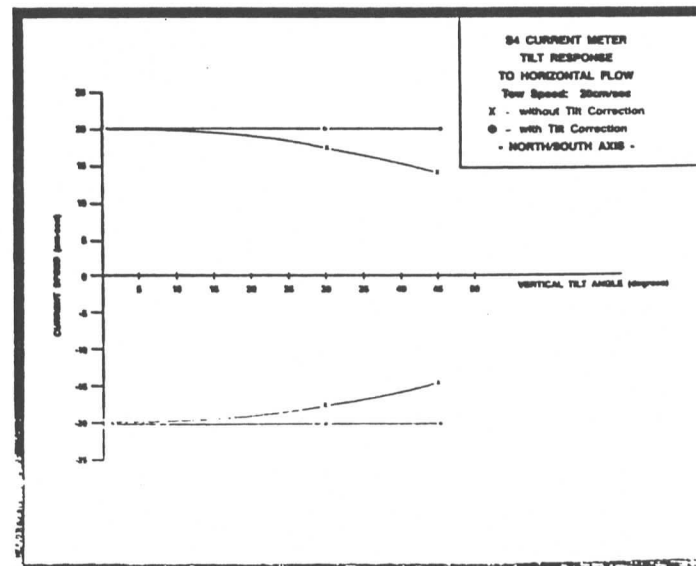
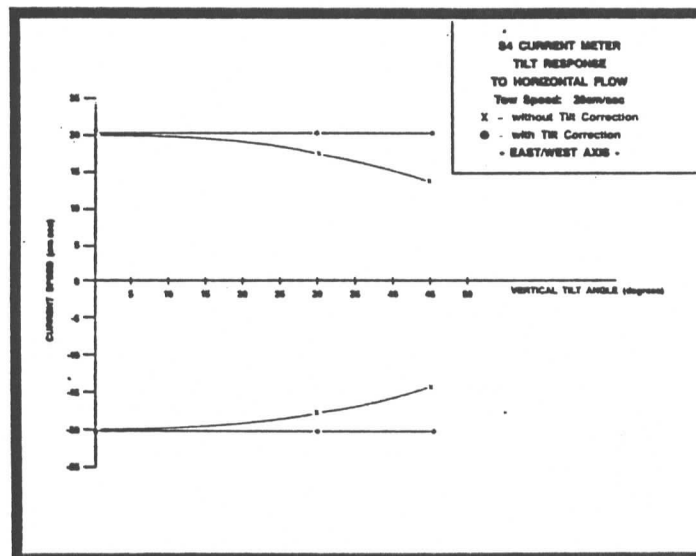

SPHERICAL SOLID STATE SENSOR CURRENT METER

ENGINEERING DATA & SPECIFICATIONS

CURRENT SPEED

TYPE: Electro-Magnetic, 2 Axis
RANGE: 0-350 cm/sec (standard)
0-50 and 0-100 cm/sec (optional)
RESOLUTION: 0.2 cm/sec (standard)
0.03 cm/sec (0-50 range)
0.06 cm/sec (0-100 range)
ACCURACY: 2% reading ± 1 cm/sec (0.03 ft/sec)
NOISE: Same as resolution for average of 1 minute or longer
0.05 cm/sec rms for 10 second averages
0.25 cm/sec rms for 2 second averages
0.75 cm/sec rms for burst sampling (0.5 sec rate)
THRESHOLD: Limited only by resolution and noise
VERTICAL RESPONSE: True cosine response (Internally software corrected with Tilt Option)

TILT COMPENSATION (OPTIONAL)

ANGLE RANGE: ± 45 degrees
RESOLUTION: 0.06 degrees
ACCURACY: (Speed Correction) $\pm 1\%$ of reading
(Angle Output) ± 0.25 degrees

DIRECTION

TYPE: Flux-Gate Compass
RANGE: 360°
RESOLUTION: 0.5°
ACCURACY: 2°
TILT: $\pm 25^\circ$ for specified accuracy

MEMORY

TYPE: CMOS static RAM (Non-restricted Lithium battery protected)
BATTERY LIFE: 5 years
CAPACITY: 64K Byte (128K or 256K Byte optional)
>87,000 vector averages may be stored with 256K bytes

TIMEKEEPING

TYPE: Temperature stable Quartz oscillator
ACCURACY: ± 12 minutes/year
POWER: Non-restricted Lithium battery (5 year life)

POWER SUPPLY

TYPE: Internal batteries (6 Alkaline "D" cells) (Lithium optional)
ENDURANCE: Lithium option—2400 hours continuous logging. Five years deployment, with on-time less than 2000 hours
Alkaline Cells—480 hours continuous logging. One year deployment with total on-time less than 480 hours.

OPTIONAL SENSORS

TEMPERATURE

TYPE: Semiconductor (Thermistor or Platinum optional)
RANGE: -5 to $+45^\circ\text{C}$
RESOLUTION: 0.05°C
ACCURACY: $\pm 0.2^\circ\text{C}$
RESPONSE TIME (63%): 1 minute (1.5 sec. Thermistor or 60 m/sec. Platinum)

CONDUCTIVITY

TYPE: Conductive
RANGE: 5-70 mS/cm
RESOLUTION: 0.1 mS/cm
ACCURACY: ± 0.2 mS/cm

PRESSURE

TYPE: Semiconductor
RANGE: 0-1000 dBar (70 M option)
RESOLUTION: 1 dBar (4 mm with 70 M option)
ACCURACY: $\pm 0.25\%$ fs

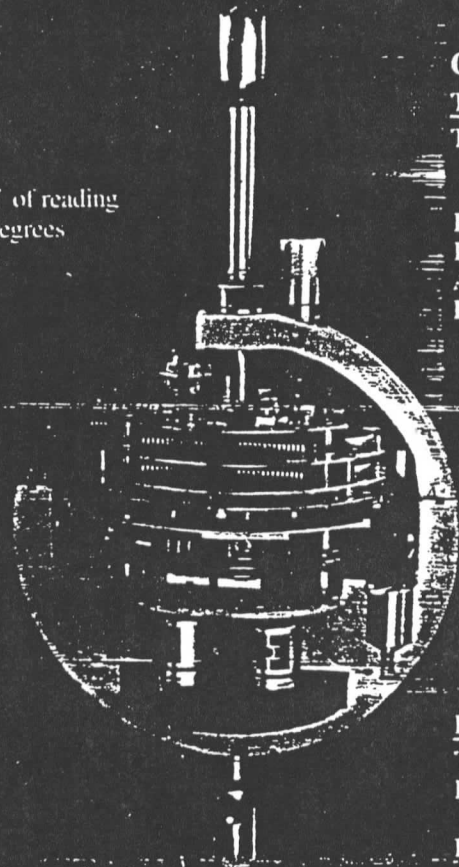

MECHANICAL

SIZE: Sphere, 25 cm (10 in.) diameter
WEIGHT: Air, 11 kg (24 lbs.); Water, 15 kg (33 lbs.)
MATERIAL: Sphere, glass-filled cycloaliphatic
INSULATION: Insulating inner shell
SHACKLE PIN: (5/8 in.) shackle pin

A MINIATURE SALINITY TEMPERATURE DEPTH PROBE

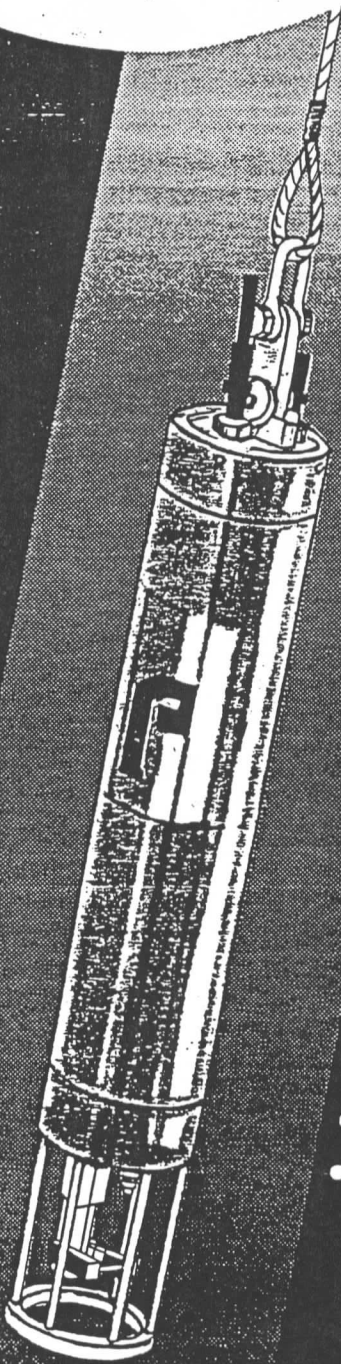

RANKED NUMBER ONE IN USER SATISFACTION

- Lifting eye to accommodate 1/2" shackle
- Sacrificial zinc anode assures season after season of corrosion free operation
- External on/off switch, positive, waterproof
- Data connector if conducting cable is to be utilized. Direct output in engineering terms via RS-232 interface or deck display
- Internal batteries
- Hardcoat anodized 6061-T6 aluminum housing engineered for 5,000 metres depth. Size: 10.2 cm diameter x 67.5 cm, 8 kg
- Applied Microsystems Ltd. logo assures innovative engineering, accurate, reliable instrumentation
- Solid state CMOS electronics, micro-processor based, programmable via RS-232 port, data in engineering terms. Salinity, Sigma 'T' computed
- Solid state memory holds 480, 2200 or 7700 samples of C, T & D. Conducting cable not required
- Sensor Protection Cage
- Sensors:
 - Conductivity
 - Temperature
 - Pressure
- Optional:
 - Dissolved Oxygen
 - Ph
 - Turbidity

DISCOVER THE REASON:

STD-12

A MINIATURE SALINITY, TEMPERATURE AND DEPTH RECORDER INCORPORATING STATE OF THE ART SENSORS

The STD-12 is a low-cost, self-contained intelligent mini CTD designed for precision measurements of seawater conductivity, temperature and pressure. Small dimensions and internal solid state memory permit small boat 'hand-hauled' profiling. The STD-12 outputs information on a 20mA current loop and can be configured for RS-232C, via the serial interface (supplied). Output information can also be configured for 'raw' integers or computed engineering values of salinity and sigma 'T'. RS-232C permits direct data transfer to most personal computers.

Upon submersion the STD-12 has the options of logging continuously, logging at user chosen pressure or time increments, or logging upon request when connected to a terminal. Sampling speeds are programmable, to a maximum of eight scans per second.

The STD-12 has the capability of high precision measurements. However, several options are available to suit the purchaser with budget constraints. Options A and B are determined by the degree of calibration.

MEASUREMENT CAPABILITY			CALIBRATION PRECISION ORDERING INFORMATION		
RANGE	ACCURACY	RESOLUTION	STANDARD	OPTION A	OPTION B
Conductivity 0 to 6 mmhos/cm	±10umhos/cm	±3umhos/cm	±0.2mmhos/cm	±20umhos/cm	±10umhos/cm
Temperature -2 to 38°C	±0.01°C	±0.005°C	±0.1°C	±0.02°C	±0.01°C

Depth accurate to .1% over range selected. (.01% optional)

Optional ranges:
(in PSI)

0-100	0-150
0-500	0-1000
0-2000	0-5000
0-7500	

Optional Sensors (maximum 8 channels total)

- Dissolved Oxygen (DO₂)
- pH
- Turbidity

Custom sensor interfaces available on request.

EXTENDED COMPUTATIONS				
PARAMETER	FORMULA	DISPLAYED PRECISION		
		STANDARD	OPTION A	OPTION B
Salinity	Practical Salinity Scale	±300ppm	±30ppm	±10ppm
		.65%	.13%	.12%
Sigma T	Knudson's			
Velocity of Sound	Wilson's	±0.7m/sec	±0.1m/sec	Better than display capability

FEATURES

- Precise 4 electrode glass conductivity cell
- 4½ digit A/D converter
- Solid State memory data storage
- Autostart when deployed in sea water
- Keyboard programmability
- 'Real' or 'raw' value output
- Minor external data processing requirements
- Atmospheric pressure offset correction
- CMOS circuitry
- Lifetime conditional warranty
- Low cost
- Minimal maintenance
- Internal batteries can be Lithium, Alkaline or Rechargeable

MEMORY: 4K RAM holds 480 data scans. 20K, 60K and extended memory options available.

OUTPUT: RS-232, 1200/300 BAUD or 20mA loop.

POWER REQUIRED: 3 × 3.9V Lithium cell 14AH. Alternate power supply upon request.

PRESSURE HOUSING: 67.5 cm × 10.2 O.D. cm Aluminum case submersible to 5000 M.

APPENDIX B

WAVE CLIMATE DATA

This appendix presents wave statistics from the wave climate station located 1.8 km off SONGS, in 12 m water depth. The instrument in use is an S-4 InterOcean current meter deployed 1.5 meters off the bottom and programmed to measure pressure and velocity. It samples for 17 minutes every 12 hours and stores 2-second averages in memory. Data are collected from the field approximately every 12 days.

Sea surface elevation spectrum is obtained from the pressure time series using linear wave theory. Coefficients from Fast Fourier Transformations are used to produce the energy spectra grouped in energy bands listed in this appendix. Units are CGS. In addition to Tot.En. (total energy is equal to the surface elevation variance) and Significant Wave Height (equal to four times the standard deviation of the sea surface elevation), velocity (mean u and mean v) and standard deviation of the current are shown. Tridimensional plots are included to display energy distribution by energy band every 12 hours. This allows one to see at a glance, the size of the waves over the given months.

Note that this presentation of the wave data is almost identical to that given in the Coastal Data Information Program publication (see US Army Corps of Eng., 1984) which gives surface wave data for the California coast, including San Clemente and Oceanside.

Wave Spectra-- SEPTEMBER 1985

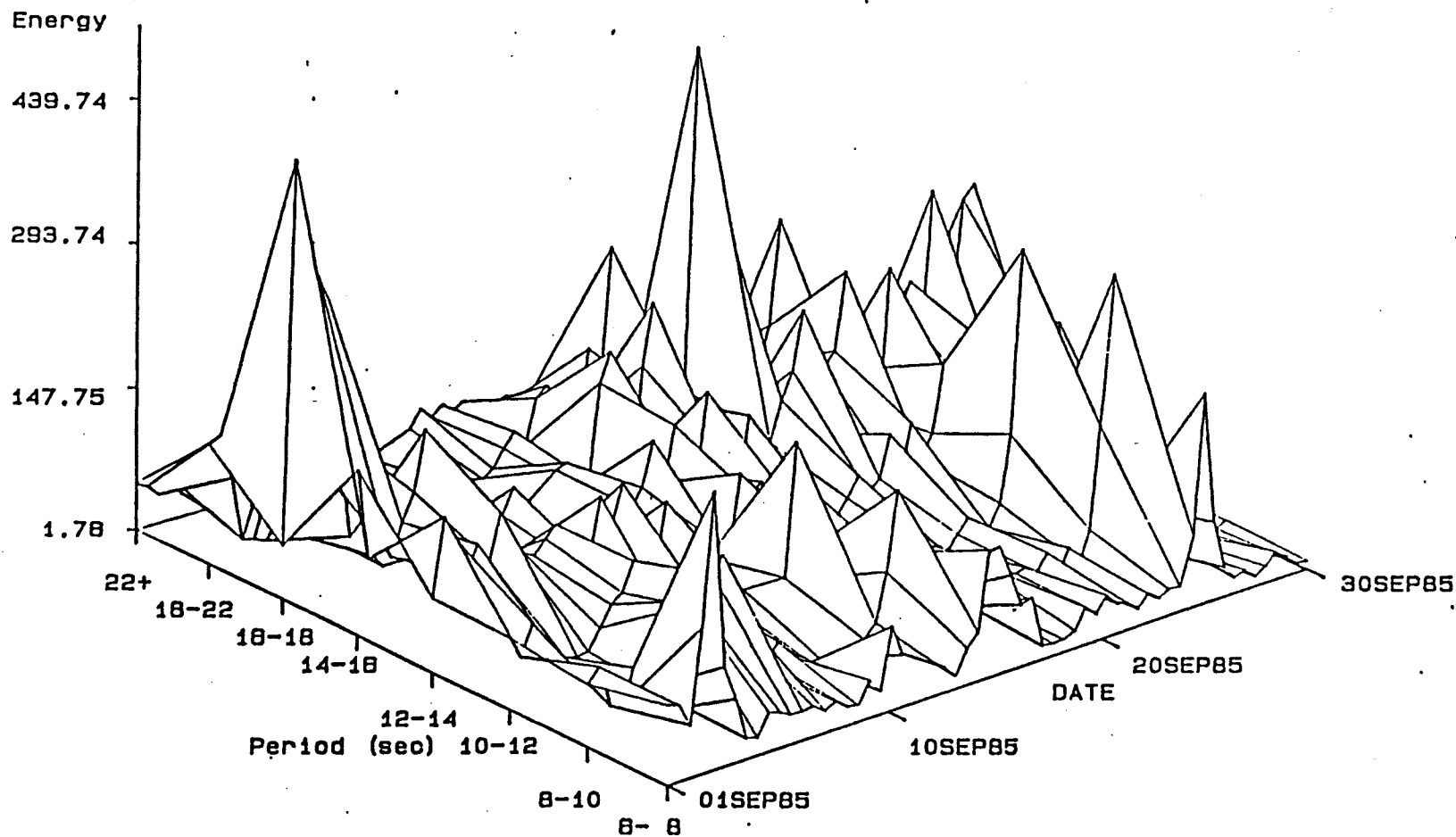

Graphical presentation of wave energy divided up into period bands and plotted against time for September 1985.

WAVE CLIMATE FREQUENCY ANALYSIS

DATE	TIME (LOCAL)	MEAN U (CM/S)	MEAN V (CM/S)	SDEV CUR (CM/S)	SIG HT (CM)	TOT EN (CM SQ)	--- PERCENT ENERGY IN BAND ---							
							22+	22-18	18-16	16-14	14-12	12-10	10-8	8-6
01SEP85	2:00	-5.00	4.00	23.26	113.68	807.66	6.3	15.4	6.8	20.7	9.1	8.7	7.7	9.7
01SEP85	14:00	6.00	0.00	27.91	135.98	1155.59	3.8	11.2	37.8	6.4	13.0	4.2	6.5	6.5
02SEP85	2:00	0.00	1.00	22.77	106.80	712.89	4.5	11.7	20.4	12.7	17.4	10.7	4.8	7.4
02SEP85	14:00	-1.00	1.00	24.78	122.51	938.09	5.1	1.8	33.7	7.3	9.4	4.9	3.3	15.0
03SEP85	2:00	-3.00	4.00	25.99	147.29	1355.98	2.0	1.0	21.2	7.4	8.3	2.9	4.7	19.9
03SEP85	14:00	-3.00	0.00	21.65	127.30	1012.85	1.8	0.8	14.8	12.6	9.0	3.3	3.9	9.6
04SEP85	2:00	-4.00	1.00	21.07	109.20	745.23	4.6	0.7	5.9	25.1	18.5	4.2	2.0	8.5
04SEP85	14:00	-1.00	3.00	19.41	94.92	563.07	5.0	0.9	14.5	19.6	18.1	5.8	4.3	4.0
05SEP85	2:00	-1.00	2.00	19.28	94.29	555.66	2.4	0.7	3.3	27.5	16.2	9.2	19.1	3.4
05SEP85	14:00	-1.00	1.00	18.75	86.08	463.07	3.7	1.3	0.7	13.2	18.0	15.3	23.7	8.6
06SEP85	2:00	-13.00	0.00	17.57	83.66	437.40	2.3	1.0	2.1	7.4	22.1	18.0	22.6	8.2
06SEP85	14:00	-12.00	0.00	18.57	91.41	522.20	3.1	2.0	3.5	3.9	20.7	20.4	24.7	5.8
07SEP85	2:00	-15.00	0.00	17.86	83.88	439.76	2.1	0.4	4.7	6.2	16.3	11.4	32.9	6.8
07SEP85	14:00	-2.00	-7.00	16.48	78.00	380.24	4.7	1.0	2.5	19.9	15.0	7.1	18.2	8.2
08SEP85	2:00	-19.00	-2.00	17.33	76.03	361.32	1.7	1.2	3.6	28.1	17.1	8.2	20.9	6.4
08SEP85	14:00	0.00	0.00	15.99	70.89	314.12	2.6	1.0	2.6	11.4	39.2	6.6	9.6	9.2
09SEP85	2:00	-14.00	2.00	14.42	66.99	280.45	1.4	0.7	5.0	11.7	31.1	7.8	10.0	7.2
09SEP85	14:00	-2.00	6.00	16.68	77.26	373.07	2.6	0.8	4.6	5.2	34.8	13.5	11.4	4.9
10SEP85	2:00	-7.00	9.00	15.27	86.35	466.01	0.8	0.4	1.3	7.4	7.2	5.6	5.6	8.3
10SEP85	14:00	0.00	4.00	12.55	75.82	359.26	1.8	0.7	0.7	3.7	9.1	6.4	6.3	6.9
11SEP85	2:00	-8.00	4.00	17.78	118.57	878.70	0.4	0.2	0.9	2.4	3.1	3.4	1.5	9.4
11SEP85	14:00	-1.00	5.00	16.34	92.73	537.42	1.0	2.5	2.3	1.6	18.2	8.1	2.0	9.8
13SEP85	12:00	4.00	4.00	15.01	72.03	324.24	7.0	1.4	14.7	13.5	8.0	13.0	5.4	8.2
13SEP85	12:00	4.00	4.00	15.01	72.03	324.24	7.0	1.4	14.7	13.5	8.0	13.0	5.4	8.2
14SEP85	0:00	-9.00	0.00	18.94	89.49	500.50	8.0	2.3	10.4	12.2	7.4	35.2	6.0	2.9
14SEP85	12:00	7.00	-3.00	17.85	85.40	455.84	6.1	6.4	4.6	23.1	4.6	7.5	16.7	8.2
15SEP85	0:00	0.00	3.00	21.56	118.29	874.51	4.3	5.0	3.1	6.8	11.8	7.4	17.8	5.6
15SEP85	12:00	6.00	2.00	23.16	113.20	800.88	3.5	3.1	15.4	14.3	9.7	2.2	11.0	15.7
16SEP85	0:00	-3.00	6.00	21.48	145.09	1315.70	2.6	5.4	11.6	4.6	6.7	1.8	3.5	9.6
16SEP85	12:00	10.00	1.00	19.82	98.78	609.85	4.1	13.3	6.5	7.3	4.8	7.9	6.8	15.5
17SEP85	0:00	-7.00	2.00	18.91	105.10	690.40	3.4	9.0	3.4	20.1	10.4	3.7	3.9	8.9
17SEP85	12:00	0.00	5.00	20.58	105.72	698.53	2.6	4.5	18.3	10.4	4.3	4.3	2.3	9.3
18SEP85	0:00	-8.00	2.00	18.47	107.31	719.73	3.7	5.6	26.4	6.6	3.0	3.1	3.1	2.1
18SEP85	12:00	-16.00	-7.00	18.08	92.38	533.44	4.0	19.8	15.8	7.2	11.1	3.8	2.9	2.5
19SEP85	0:00	-10.00	-4.00	17.55	82.35	423.79	4.0	12.5	19.2	24.0	7.3	7.6	3.2	3.4
19SEP85	12:00	11.00	2.00	20.56	99.83	622.85	5.1	32.7	14.3	13.4	4.3	4.0	5.8	3.0
20SEP85	0:00	-11.00	-4.00	23.74	125.46	983.75	2.4	0.7	44.7	6.8	4.5	2.6	3.6	3.9
20SEP85	12:00	5.00	-3.00	24.29	114.78	823.37	2.6	1.1	38.9	13.0	7.8	3.1	4.0	3.5
21SEP85	0:00	-1.00	-2.00	19.89	91.65	524.95	3.0	0.8	7.3	25.5	8.4	3.0	6.8	8.2
21SEP85	12:00	-6.00	-2.00	18.86	98.82	610.35	3.7	1.4	4.4	31.6	8.9	5.0	4.5	5.2
22SEP85	0:00	-9.00	1.00	19.97	103.60	670.85	1.4	5.0	9.0	9.2	14.4	6.6	6.4	4.3
22SEP85	12:00	2.00	4.00	19.77	91.36	521.65	3.3	7.0	18.9	24.3	8.4	6.8	3.2	3.7
23SEP85	0:00	-14.00	-1.00	20.39	101.98	649.95	1.7	7.4	14.0	21.7	15.6	4.1	6.3	4.7
23SEP85	12:00	-7.00	5.00	21.25	103.81	673.56	3.0	7.9	19.3	32.5	9.0	7.3	3.2	3.3
24SEP85	0:00	-12.00	2.00	21.79	108.36	733.87	1.9	0.9	32.2	10.7	11.4	15.9	7.2	3.8
24SEP85	12:00	0.00	4.00	26.72	128.48	1031.77	2.7	0.6	14.7	11.0	14.7	29.1	15.2	2.6
25SEP85	3:00	-7.00	2.00	25.86	116.16	843.38	2.1	0.5	19.3	6.4	6.0	8.7	36.1	8.7
25SEP85	15:00	-6.00	5.00	24.22	110.08	757.34	1.4	0.5	5.9	27.6	12.9	2.6	8.2	28.4
26SEP85	3:00	-7.00	1.00	21.59	106.60	710.16	6.8	1.0	4.4	23.5	14.4	6.6	8.9	11.5
26SEP85	15:00	6.00	-1.00	22.38	92.23	531.65	1.2	1.6	3.0	35.6	29.5	5.3	2.8	6.0
27SEP85	3:00	1.00	1.00	17.66	83.06	431.15	2.0	3.7	7.0	25.5	18.6	5.7	7.3	4.1
27SEP85	15:00	6.00	2.00	21.10	92.23	531.68	1.6	2.6	6.5	51.8	16.2	1.8	2.3	4.1
28SEP85	3:00	1.00	3.00	21.25	89.46	500.22	1.6	1.6	11.0	19.0	32.1	8.5	2.5	2.5
28SEP85	15:00	6.00	-5.00	18.45	88.67	491.37	1.3	0.6	9.8	33.8	15.9	5.8	1.6	3.8
29SEP85	3:00	-3.00	0.00	22.02	101.13	639.25	1.5	0.3	5.3	40.3	22.9	3.3	1.9	4.7
29SEP85	15:00	3.00	0.00	20.62	91.74	526.04	1.3	0.6	6.9	51.2	14.7	4.9	1.8	4.2
30SEP85	3:00	4.00	-1.00	19.73	85.40	455.82	2.5	0.8	7.3	30.9	14.1	6.1	2.6	2.6

Data computed for wave climate information during September 1985. Shown are the mean cross shore (U) and longshore (V) current, the standard deviation of the current speed (SDEV CUR), significant wave height (SIG HT), total energy of the sea surface elevation spectrum (TOT EN), and percent of this energy present in the various period bands

LIST OF FIGURES

Figure 1: Data Flow Diagram.

Figure 2 (a,b): Examples of processed current meter data.

Figure 3: Flow of Basic Steps for CM-P and CTD-P programs.

Figure 4: Example of InterOcean Systems, Inc. programs.

Figure 5: Schematic of a typical current meter - CTD station.

Appendix G

CLARK COUNTY WATER QUALITY STANDARDS REVIEW
PRELIMINARY SCOPE OF WORK--PHASE II

TASK 1--PROJECT MANAGEMENT AND COORDINATION

This task will be used to direct and coordinate Phase II task elements within the consultant team members and offices and to provide project coordination with the County staff, including technical investigations, reporting, review meetings, and presentation materials.

TASK 2--WQS DECISION MATRIX DEVELOPMENT

Objective

The purpose of this task is to develop a qualitative annotated decision matrix of the procedures used by NDEP in developing the standards and TMDL's for Las Vegas Wash/Lake Mead. The matrix can be used to enumerate the relative nature of the processes in terms of conservatism.

Approach

Significant data use assumptions, analysis assumptions, data biases, mathematical restrictions, and other pertinent components of the state's WQS development process will be delineated, and a qualitative description that will describe each item in relation to its conservative impact on the standards or the TMDL's will be assigned. The items should include but not be limited to diurnal temperature and pH data, TDS levels, sensitive organisms, site-specific bio-assay data, dilution factors, periods of analysis, data averaging, extent of data, and sampling protocol.

TASK 3--NDEP DILUTION MODEL SENSITIVITY ANALYSIS

Objective

The purpose of this task is to investigate the sensitivity of the independent variables in the dilution model as they relate to the establishment of TMDL's at NSR. The independent variables and the impacts evaluation will be restricted to those ranges expected to exist within the limits of the Las Vegas Bay/Wash system. The sensitivity information will be related to the decision matrix, assumptions, data, and bias to demonstrate and identify those decision components having the most effect on the proposed standards or TMDL's.

Approach

The methods of the sensitivity analysis will be to examine each independent variable while holding all others constant. A matrix or graphical display of the results will be developed to show the sensitivity of the data or variables on the outcome (TMDL's at NSR). The approach in the analysis will be the same as the NDEP to maintain consistency.

TASK 4--STATISTICAL EVALUATION OF NDEP MODEL

Objective

The purpose of this task is to examine the performance of the NDEP simplified dilution model in estimating surface concentrations in Las Vegas Bay. The model has been directly used to determine the dilution between NSR and the control stations (BC2 to BC5). The dilution factors are integral components in the NDEP procedures for estimating the surface concentrations at the control stations.

The calibration performance of the model will be used to estimate surface concentrations for both total phosphorus and total ammonia. Then the predictive power of the model will be checked by examining its ability to use the calibrated dilution factors to predict the surface concentrations for 1986 daily sampled data in the bay.

Approach

Using the available historic data, the dilution factors for both total ammonia and total phosphorus as developed by NDEP will be checked. Any dilution factors will be corrected as necessary and those changes incorporated into the final estimates of the calibrated dilution factors. The 1981-85 data should be used for total phosphorus, and the 1979-85 data should be used for the total ammonia, in accordance with NDEP's procedures. Using these monthly (ammonia) or seasonal (phosphorus) dilution factors and the daily concentrations of total ammonia or total phosphorus at NSR, an estimate of surface concentrations at the control stations in Las Vegas Bay will be computed. The computed surface concentrations will be compared with the sampled surface concentrations, correlation and calibration statistics will be developed for total ammonia and total phosphorus.

The model variability and capability to estimate the surface concentrations in Las Vegas Bay during the historic calibration data base period will be discussed.

Using the resulting dilution factors and the 1986 sampling data base, the surface concentrations for each 1986 sampling day will be estimated. Predictive power statistics on the 1986 data for both total ammonia and total phosphorus will be developed.

TASK 5--WETLANDS IN LAS VEGAS WASH

Objective

This task will determine the time variability of the area of wetlands in the Las Vegas Wash and will provide an estimate of the extent to which they were involved in filtering the treated effluent. The adjacent riparian uplands will be included if they appear significant from a soil volume-filter basis. The period of interest will be from approximately 1970 to 1987. Changes in the utilization and extent of wetlands will be estimated.

Approach

Aerial photography and planimetry will be used to quantify the wetlands and interpret the extent of utilization for treated effluent filtering. Some stereo pairs will be required at a suitable scale to identify which areas are (or were) wetlands. Acreages of the wetlands ^{and} on adjacent riparian uplands, if significant, will be estimated for various years. Losses due to erosion and sedimentation processes over time will be calculated. Delta formation and changes in the Upper Las Vegas Bay may also be useful in relating soil losses and changes in the wash.

Photos from the County, City of Las Vegas, UNLV, Bureau of Reclamation, and perhaps the Bureau of Land Management will be thoroughly examined to find appropriate stereo pairs. These should be borrowed and brought back to the office for detailed photogrammetric analysis. Pre-1970 photos may be used if they are beneficial in identification of the wetlands location. Possibly nonstereo photos may be used in the trend-loss analysis once basic identification is established over the period of interest.

The results of this task will produce a chronological evaluation of the extent of wetlands and riparian uplands, the losses and transformation history of the past 15+ years, and the trends of the amount of wetlands used in filtration of treated effluent through Las Vegas Wash.

TASK 6--DIURNAL AND LATERAL VARIATIONS IN SURFACE
CONCENTRATIONS AND EMPIRICAL BENTHIC STUDIES OF LAS VEGAS
BAY

Objective

The purpose of these fields studies is to establish the extent of variation in surface concentrations of total ammonia, total phosphorus, temperature, TDS, and pH. The variations are expected to exist laterally across the bay, longitudinally along the principal axis, and over time throughout the day. The amount of variation is critical to the establishment of the standards and TMDL's. Additionally, the status of the benthic community can be examined during the field surveys as an indication of the health and risk to the present levels of effluent discharge.

Approach

Preferably, the sampling protocol will be established similar to recent methods as 2.5 m depth integrated samples. Four fixed stations across each cross section will be used, with one floating site used to follow the plume. Thus, five surface samples will be taken for each section and one in the plume. The sections to be evaluated should coincide with those used in the previous NDEP analysis (i.e., BC2 to BC5). To examine diurnal effects, it is suggested that sampling be repeated every 3 hours if physically possible.

Two two-man crews are expected to be required and equipped with appropriate probe instruments for rapid analysis of pH, temperature, conductivity, and DO. Bottled samples will be taken, fixed, and stored until the entire sample run is concluded. Each intensive survey will be performed for 48 hours during each of the three seasons (e.g., spring, approximately May; summer, approximately July; fall, approximately October).

The benthic survey can be done any time during the above activities but preferably during the daytime. Six grab samples are suggested at two stations during the three seasons identified for the diurnal studies. The samples will be sieved and washed in the field. The organisms captured will be put into jars, labeled, preserved, and sent to the laboratory.

In the laboratory, the lowest practical taxon will be identified and counted, and the volumetric displacement or wet weight will be determined. The diversity index will be calculated; stations compared; and community structures compared to taxonomic, diversity, and abundance indicators.

TASK 7--CHRONIC TOXICITY BIOASSAY STUDIES

Objective

This task will be directed primarily towards establishing the site-specific toxicity levels of several important, sensitive Lake Mead/Las Vegas Bay species to treated effluent. This information can then be used to calculate the required TMDL's at NSR. Secondly, acute toxicity levels for some species will be established, if it is appropriate, along with cross-referenced toxicity information to other species. Site-specific acute-to-chronic ratios will be developed for application in the development of the receiving water standards.

Approach

A laboratory trailer devoted to bioassays will be set up onsite near the shores of Lake Mead so that Lake Mead control water can be used. This is critical because un-ionized ammonia is the toxicant of concern, and it is environmentally reactive in the receiving water. The receiving water effect is important in the equation for deriving toxicity to the various organisms.

TASK 8--REVIEW OF LAS VEGAS BAY SAMPLING PROGRAMS

The chemical and biological sampling needs in Las Vegas Bay will be reviewed to answer the questions of lateral dilution variability, toxicity, diurnal effects of pH and temperature on un-ionized ammonia, indications of system stress, and related biological factors. This task provides for further identification and discussion of data needs, both in-house and with the County, and will fine tune the sampling program to acquire the necessary information.

TASK 9--REPORTING OF PHASE II RESULTS

Data, information, and results of the Phase II WQS project will be submitted in draft format as in Phase I. One review and revision by the County will be used to incorporate comments into a final report. Consultant's in-house review will be included in both the draft and final reports.

TASK 10--MEETINGS WITH CLIENT

Three trips to Las Vegas will be needed to attend meetings with County staff and others. Each trip will be expected to require 1-1/2 days per person (1/2 day travel and 1 day in Las Vegas), and three people will be expected to attend each meeting.

Should additional meetings be required, they will be outside Task 10 and will be compensated for separately.

PRELIMINARY PHASE II TIME AND COST ESTIMATE

Task	Personnel Level					Total Staff Days	Total Labor	Total Expense	Total Cost
	E-6/7	E-4/5	E-2/3	W.P.	Tech				
1	1	5	-	3	2	11	\$ 4,735	\$ 700	\$ 5,435
2	2	4	-	1	-	7	3,945	1,500	5,445
3	3	7	3	-	-	13	7,430	1,500	8,930
4	2	10	14	-	3	29	14,255	2,500	16,755
5	1	5	5	1	-	12	5,945	800	6,745
6	1	12	30	6	33	82	33,960	64,300	98,260
7	5	-	335	15	-	355	152,925	64,500	217,425
8	3	3	1	2	1	10	5,155	1,500	6,655
9	6	14	5	18	2	45	19,385	2,000	21,385
10	<u>9</u>	<u>5</u>	<u>-</u>	<u>-</u>	<u>-</u>	<u>14</u>	<u>9,415</u>	<u>4,000</u>	<u>13,415</u>
Total	33	65	393	46	41	578	\$257,150	\$143,300	\$393,705

RD/R86/074